



Standard Burner Systems:

- PB-**(P)A
- PB**-01(M)(P)
- PB**-11(M)(P)
- PB**-15(M)(P)
- PB**-17(M)(P)

****Sizes:
(18, 24, 30)**



**DESIGN CERTIFIED
to
Vented Decorative Appliance
ANSI Z21.60-2012
CSA 2.26-2012**

**FOR INSTALLATION IN
SOLID-FUEL BURNING
FIREPLACES***

**FOR USE WITH
FYRE GLASS / FYRE GEMS**

PB SERIES VENTED GAS BURNER SYSTEMS (REGULATED)

WARNING

If the information in this manual is not followed exactly, a fire or explosion may result, causing property damage, personal injury, or loss of life.

Do not store or use gasoline or other flammable vapors and liquids in the vicinity of this or any other appliance.

WHAT TO DO IF YOU SMELL GAS:

- **Open a window.**
- **Do not try to light any appliance.**
- **Do not touch any electrical switch; do not use any phone in the building.**
- **Immediately call the gas supplier from a neighbor's phone. Follow gas supplier's instructions.**
- **If you cannot reach the gas supplier, call the fire department.**

Installation and service must be performed by a qualified professional installer, service agency, or the gas supplier.

This appliance is only for use with the type of gas indicated on the rating plate.

IMPORTANT: READ THESE INSTRUCTIONS CAREFULLY BEFORE STARTING INSTALLATION OF THE SYSTEM

The Real-Fyre gas burner system is to be installed only in a solid-fuel burning fireplace with a working flue and constructed of noncombustible material. The installation, including provisions for combustion and ventilation air must conform with the *National Fuel Gas Code, ANSI Z223.1/NFPA 54*, or the *CSA B149.1, Natural Gas and Propane Installation Code*, and applicable local building codes.

A damper clamp is included to maintain the minimum permanent vent opening and to prevent full closure of the damper blade. **The chimney damper MUST be fully opened when burning the burner system. The burner system is designed to burn with yellow flames; thus adequate ventilation is absolutely necessary.**

To comply with certification, listings, and building code acceptances, and for safe operation and proper performance of this burner system, use ONLY Peterson parts and accessories. Use of other controls, parts, and accessories that are not designed for use with Real-Fyre gas burner systems is prohibited and will void all warranties, certifications, listings, and building code approvals, and may cause property damage, personal injury, or loss of life.

***Note:** Solid-fuels shall not be burned in a fireplace where a decorative appliance is installed.



We recommend that our gas hearth products be installed and serviced by professionals who are certified in the U.S. by the National Fireplace Institute® (NFI) as NFI Gas Specialists.

**INSTALLER:
Leave this manual with the appliance.
CONSUMER:
Retain this manual for future reference.**



Systèmes standard de brûleur:

PB-**(P)A
PB-**-01(M)(P)
PB-**-11(M)(P)
PB-**-15(M)(P)
PB-**-17(M)(P)

**Sizes:
(18, 24, 30)



CONCEPTION CERTIFIÉE

à
Vented Decorative Appliance
ANSI Z21.60-2012
CSA 2.26-2012

**POUR L'INSTALLATION EN
CHEMINÉES BRÛLANTES DE
COMBUSTIBLE SOLIDE***

**POUR L'USAGE AVEC
VERRE/GEMMES**

SYSTÈMES EXHALÉS PAR SÉRIE DE BRÛLEUR À GAZ DE PB (RÉGLÉS)

AVERTISSEMENT

Si l'information en ce manuel n'est pas suivie exactement, un incendie ou une explosion peut résulter, entraînant des dégâts matériels, des blessures, ou la perte de la vie.

Ne stockez pas ou n'employez pas l'essence ou d'autres vapeurs et liquides inflammables à proximité de ceci ou d'aucun autre appareil.

CE QUI À FAIRE SI VOUS SENTEZ LE GAZ:

- Ouvrez une fenêtre.
- N'essayez pas de n'allumer aucun appareil.
- Ne touchez aucun commutateur électrique; n'utilisez aucun téléphone dans le bâtiment.
- Appelez immédiatement le fournisseur de gaz du téléphone du voisin. Suivez les instructions du fournisseur de gaz.
- Si vous ne pouvez pas atteindre le fournisseur de gaz, appelez le département de feu.

L'installation et le service doivent être assurés par un installateur qualifié et professionnel, l'agence de service, ou le fournisseur de gaz.

Cet appareil sert seulement avec le type de gaz indiqué de la plaque de contrôle.

INSTALLATEUR :

Laissez ce manuel avec l'appareil.

CONSOMMATEUR:

Maintenez ce manuel pour la future référence.



IMPORTANT: LISEZ CES INSTRUCTIONS SOIGNEUSEMENT AVANT DE COMMENCER L'INSTALLATION DU SYSTÈME.

Le Vrai-Fyre système de brûleur à gaz doit être installé seulement dans une cheminée brûlante de combustible solide avec une conduite de cheminée fonctionnante et être construit avec du matériel non-combustible. L'installation, y compris des dispositions pour l'air de combustion et de ventilation doit se conformer au code national de gaz de carburant, la norme ANSI Z223.1/ NFPA 54, ou le CSA B149.1, code d'installation de gaz naturel et de propane, et codes du bâtiment locaux applicables.

Une bride plus humide est incluse pour maintenir l'ouverture permanente minimum de passage et pour empêcher la pleine fermeture de la lame plus humide. L'amortisseur de cheminée DOIT être entièrement ouvert en brûlant le système de brûleur. Le système de brûleur est conçu pour brûler avec les flammes jaunes ; ainsi à ventilation proportionnée est absolument nécessaire.

Pour se conformer à la certification, les listes, et les acceptations de codes du bâtiment, et pour l'exploitation sûre et l'exécution appropriée de ce système de brûleur, utilisent SEULEMENT des pièces et des accessoires de Peterson. L'utilisation d'autres commandes, pièces, et accessoires qui ne sont pas conçus pour l'usage avec de Vrais-Fyre systèmes de brûleur à gaz est interdite et videra toutes les garanties, certifications, listes, et approbations de codes du bâtiment, et peut causer des dégâts matériels, le dommage corporel, ou des pertes humaines.

*Note: Des Plein-carburants ne seront pas brûlés dans une cheminée où un appareil décoratif est installé.

TABLE OF CONTENTS

4	PARTS LIST
5	SAFETY CONTROL SYSTEM FOR MANUAL VALVE
5	SAFETY CONTROL SYSTEM FOR 11 VALVE
6	SAFETY CONTROL SYSTEM FOR 01 VALVE
6	SAFETY CONTROL SYSTEM FOR 15 VALVE
7	SAFETY CONTROL SYSTEM FOR 17 VALVE
8	IMPORTANT INFORMATION
9	IMPORTANT PRE-INSTALLATION AND FIREPLACE SAFETY INFORMATION
11	FIREPLACE OPERATING SAFETY INFORMATION
13	GLASS / GEMS QUANTITY DETERMINATION
14	INSTALLATION
14	INSTALLING THE BURNER
15	01 VALVE MODELS ONLY
15	CONNECTING THE IGNITION PACK TO THE VALVE
15	INSTALLING OR REPLACING BATTERIES FOR IGNITION MODULE PACK
15	SWITCH BOX PLACEMENT
16	NOTES PAGE
17	GLASS / GEMS PLACEMENT
17	BURNER PREPARATION
19	LIGHTING INSTRUCTIONS - MANUAL PILOT AND SERIES 17 VALVE
21	LIGHTING INSTRUCTIONS - SERIES 11 VALVE
23	LIGHTING INSTRUCTIONS - SERIES 15 VALVE
25	LIGHTING INSTRUCTIONS - SERIES 01 VALVE
26	CLEANING AND SERVICING
26	MAINTENANCE
26	CLEANING
26	SERVICING
26	FLAME DESCRIPTION
27	PILOT BURNER ADJUSTMENT (IF EQUIPPED)
28	TROUBLESHOOTING
30	WARRANTY

PARTS LIST

Before installation, check that your gas burner system is complete. See the PARTS LIST below. If any parts are missing or damaged, contact your Real-Fyre® dealer before installing or using the burner. Be sure you know the model and size of your set when ordering options or replacement parts and accessories.

Item	Description	18" model		24" model		30" model	
		Part No.	Qty.	Part No.	Qty.	Part No.	Qty.
1.	Burner pan	PB-18F	1	PB-24F	1	PB-30F	1
2.	Heat shield (see inset)	--	--	--	--	--	--
3.	Control valve (see inset)	--	--	--	--	--	--
4.	Flex connector w/ adapter	CK-5-SP	1	CK-5-SP	1	CK-5-SP	1
5.	Damper clamp	DC-1	1	DC-1	1	DC-1	1
6.	Select sand granules (natural gas) or Vermiculite granules (propane gas)	CS-10 LF-15-7	1	CS-15 LF-15-7	1	CS-10 LF-15	2

See your local dealer for replacement parts.

Note: Photos not to scale.

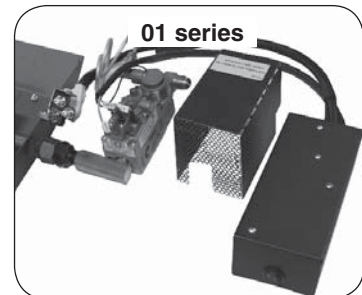
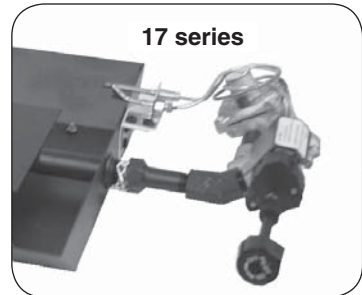
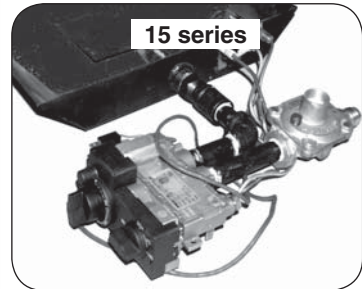
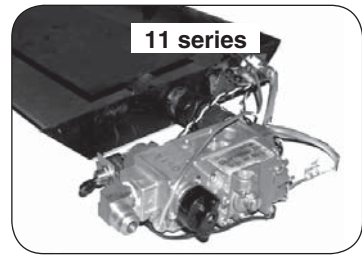
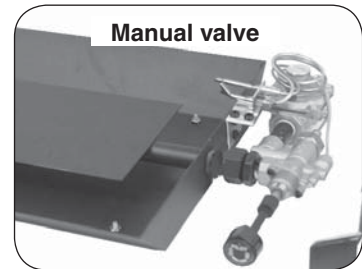
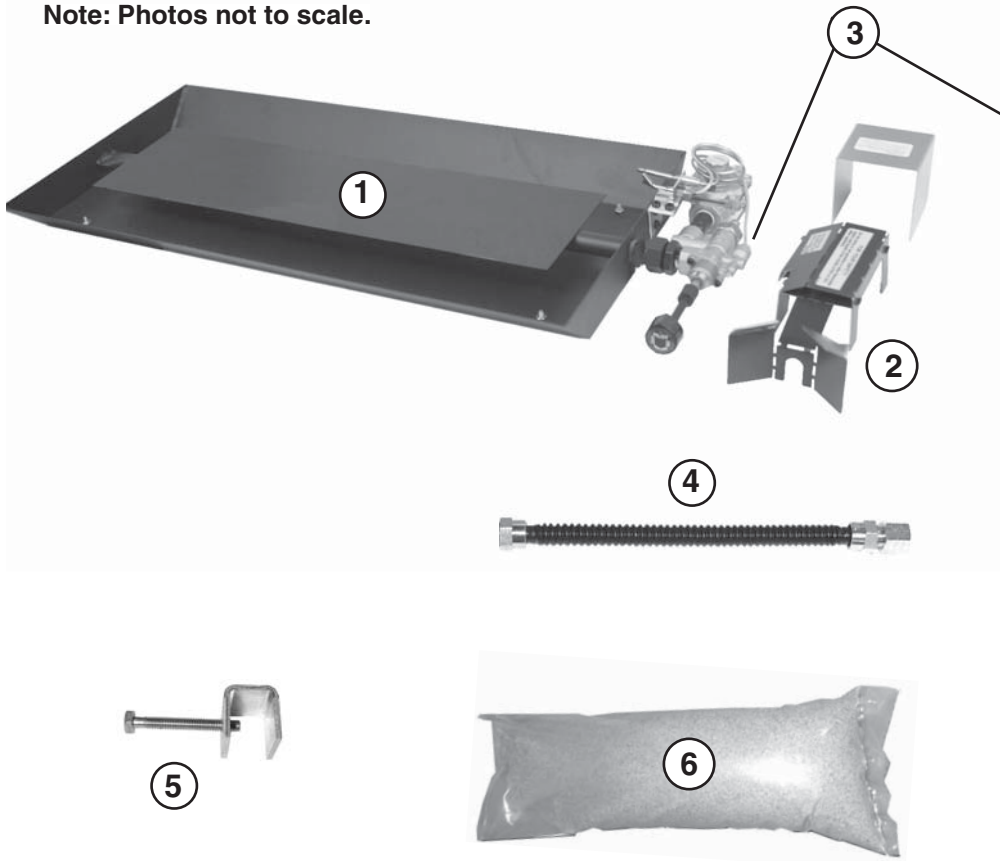

Glass / gems are purchased and packaged separately. Quantity will vary, depending on selection. Glass and gems are available in various colors; contact your dealer for further details.

For all valves, see detailed information on the following pages.

SAFETY CONTROL SYSTEM FOR MANUAL VALVE

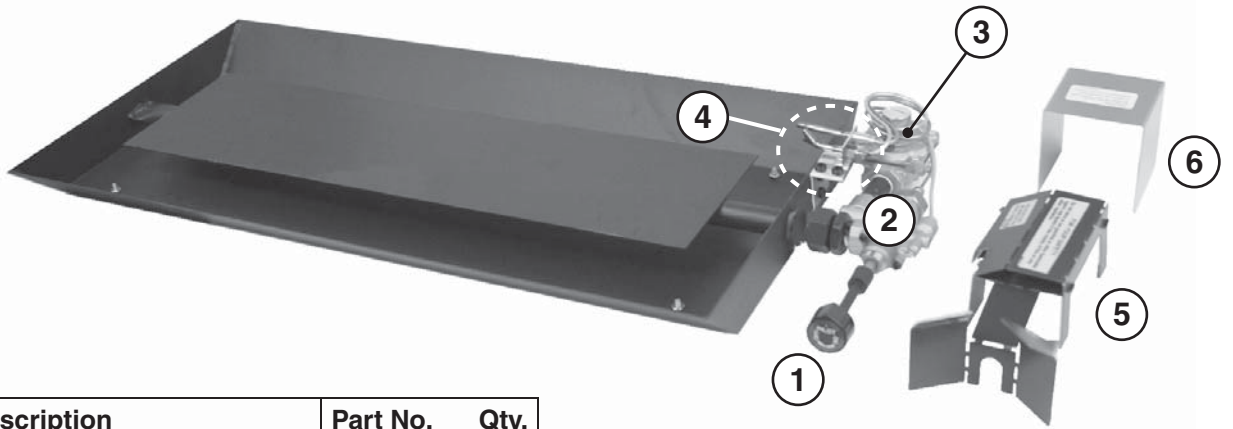

Item	Description	Part No.	Qty.
1.	Control knob	KNOB-6	1
2.	Manual SPK valve	SV-19	1
3.	Pressure regulator, natural gas or Pressure regulator, propane gas	PR-3NAT PR-2LP	1
4.	Pilot assembly, natural gas or Pilot assembly, propane gas	PT-1NAT PT-1LP	1
5.	Heat shield, valve	HS-32	1
6.	Heat shield, regulator	HS-39	1

**DO NOT REMOVE
HEAT SHIELD**

SAFETY CONTROL SYSTEM FOR 11 VALVE

Item	Description	Part No.	Qty.
1.	Valve assembly (natural) or Valve assembly (propane)	SV-6 SV-6P	1
2.	Pilot assembly (natural) or Pilot assembly (propane)	PAC-3NAT PAC-3LP	1
3.	Remote kit (if equipped)	RR-1A	1
4.	Heat shield	HS-45	1

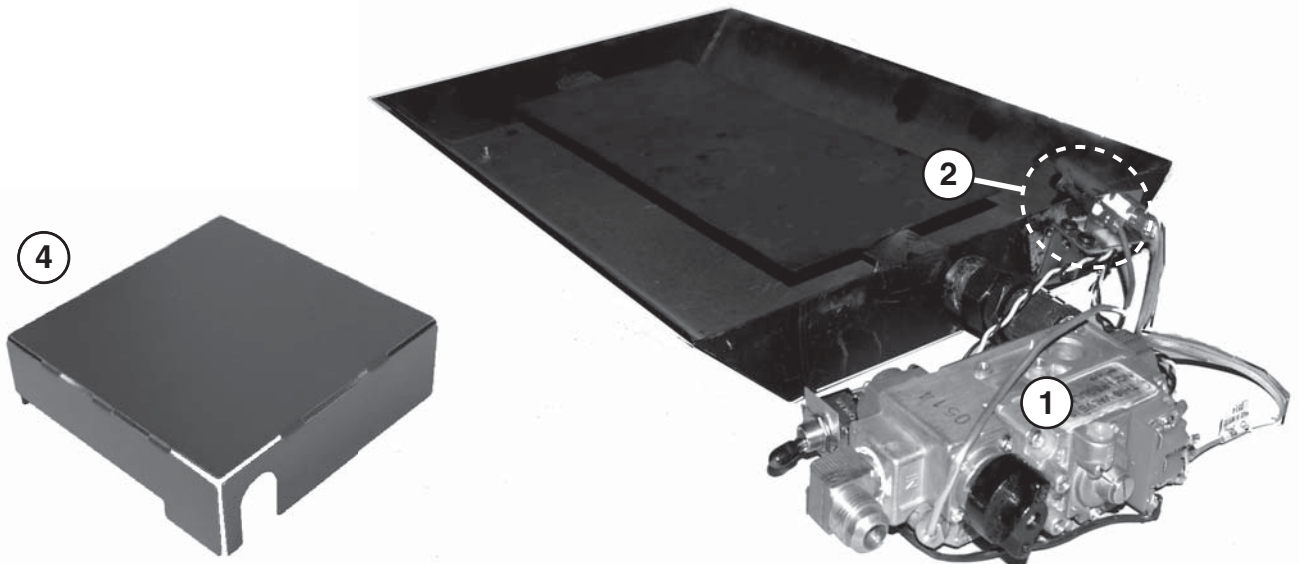

**DO NOT REMOVE
HEAT SHIELD**

SAFETY CONTROL SYSTEM FOR 01 VALVE

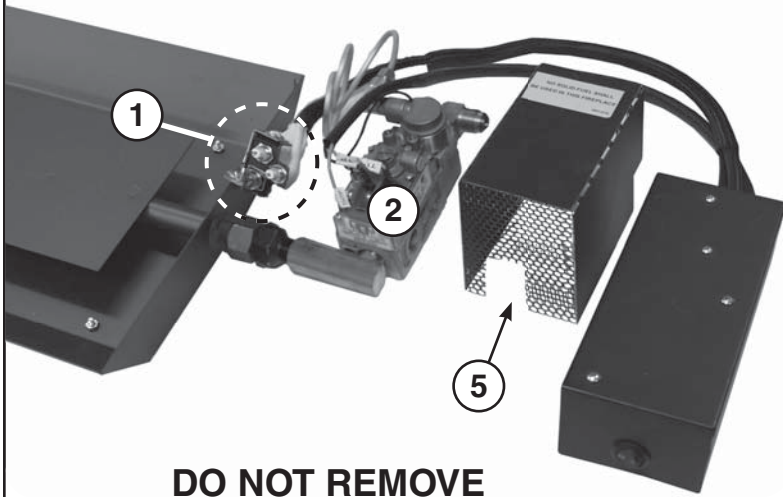

Item	Description	Part No.	Qty.
1.	Pilot assembly (natural) or Pilot assembly (propane)	PAC-6 PAC-7	1
2.	Valve assembly (natural) or Valve assembly (propane)	SV-32 SV-33	1
3.	Switch box assembly	IMP-1	1
4.	Remote kit (if equipped)	RR-1A	1
5.	Heat shield	HS-37	1

**DO NOT REMOVE
HEAT SHIELD**

**PB burner showing 01 valve layout
under heat shield**



SAFETY CONTROL SYSTEM FOR 15 VALVE

**VR-1A remote with receiver, heat shield,
batteries, & wiring (if equipped)**



**PB burner showing 15 valve layout
under heat shield**

DO NOT REMOVE HEAT SHIELD

Item	Description	Part No.	Qty.
1.	Pressure regulator, natural gas or Pressure regulator, propane gas	PR-3NAT PR-2LP	1
2.	Pilot assembly (natural gas) or Pilot assembly (propane gas)	PT-1NAT PT-1LP	1
3.	Valve, natural gas or Valve, propane gas	SV-22 SV-23	1
4.	Remote kit (if equipped)	VR-1A	1
5.	Heat shield, valve	HS-38	1
6.	Heat shield, regulator	HS-39	1

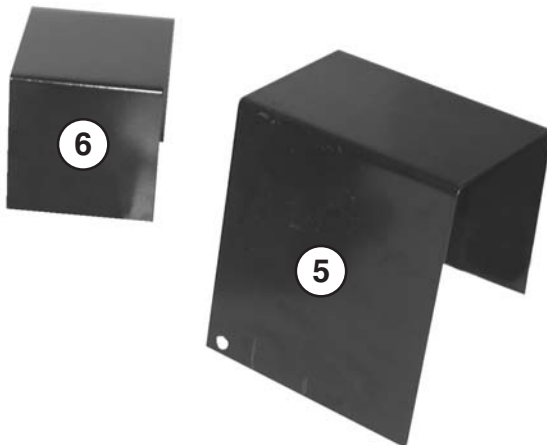
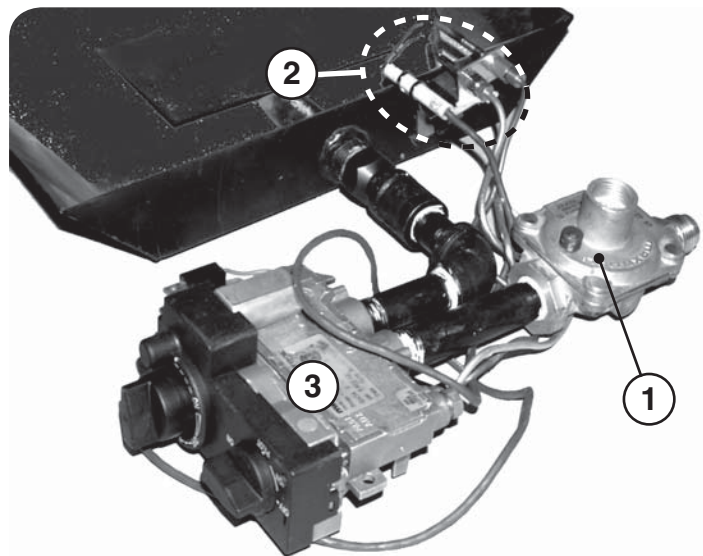

SAFETY CONTROL SYSTEM FOR 17 VALVE

Item	Description	Part No.	Qty.
1.	Valve	SV-37	1
2.	Pilot assembly, natural gas	PT-1NAT	1
or	Pilot assembly, propane gas	PT-1LP	1
3.	Pressure regulator, natural gas	PR-3NAT	1
or	Pressure regulator, propane gas	PR-2LP	1
4.	Control knob	KNOB-9	1
5.	Remote kit (if equipped)	VR-1A	1
6.	Heat shield, valve	HS-35	1
7.	Heat shield, regulator	HS-39	1

VR-1A remote with receiver, heat shield, batteries, & wiring (if equipped)



Optional manual system or upgrade to VR-2 remote system.

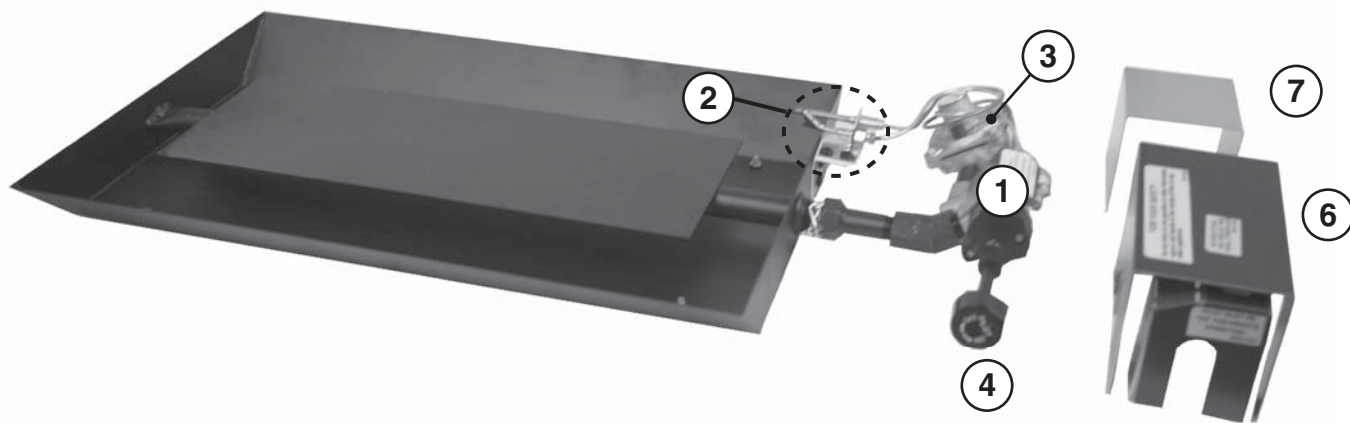

**DO NOT REMOVE
HEAT SHIELD**

IMPORTANT INFORMATION

Do not use this burner system if any part has been underwater. Immediately call a qualified professional service technician to inspect the appliance and to replace any part of the control system and any gas control which has been underwater.

The gas burner system must be isolated from the gas supply piping system by closing its individual shut-off valve during any pressure testing of the gas supply system at test pressures equal to or less than 1/2 psig. The gas burner system and its individual shut-off valve must be disconnected from the gas supply piping system when testing at pressures in excess of 1/2 psig.

Keep the area of the gas burner system clear and free from combustible materials, gasoline, and other flammable vapors and liquids.

Burner size	Min. Fireplace Dimensions			BTU	
	Width*	Depth	Height		
18"	28"	16"	18"	75k	60k
24"	34"	16"	18"	90k	75k
30"	40"	16"	18"	110k	90k

* This required width allows for centering of the system.

Important: For safe operation and proper performance and to comply with CSA Certification, **ONLY** Robert H. Peterson parts and accessories must be used with this gas burner system.

The minimum inlet gas supply pressure for purpose of input adjustment is 5" for natural gas and 11" for propane gas. Maximum inlet gas supply pressure for this burner is 10.5" for natural and 13" for propane gas.

Gas supply pipe must be 1/2" minimum interior diameter or larger. If the gas line is longer than 20', a larger diameter line may be necessary.

A fireplace screen must be in place when the system is burning. Provisions for adequate combustion air must be maintained. Unless other provisions for combustion air are provided, the screen shall have an opening(s) for introduction of combustion air. Combustion air is adequate when all flames curl into the fireplace and away from the screen. **When a glass fireplace enclosure (door) is used, leave the doors fully open when the system is in operation.**

The minimum firebox dimensions in which the burner system is certified to be installed, is listed in the Technical Data Table here.

Note: For remote ready units, the maximum BTU thru put of some valves may vary.

Minimum Free Opening Area of Chimney Damper for Venting (sq. in.)						
	For Factory-Built Fireplaces			For Masonry-Built Fireplaces		
Chimney	18"	24"	30"	18"	24"	30"
15' (min.)	36	46	52	46	55	65
20'	29	38	46	43	50	59
25'	26	32	43	-	-	-
30'	23	29	38	39	45	53

Note: The minimum chimney height from hearth to top of chimney is 15'.

IMPORTANT

For all valves, the air **MUST** be purged from the gas line before the pilot will light and burn properly. The time needed to purge will depend on the length of the gas line to the unit and the amount of time since the unit or gas line was last used. It may take several minutes before all the air is purged and the pilot will light and burn properly. Follow the LIGHTING INSTRUCTIONS section in this manual.

IMPORTANT PRE-INSTALLATION AND FIREPLACE SAFETY INFORMATION

- CAUTION:** Installation and repair must be done by an NFI Certified or other qualified professional installer.
- Installer:** Carefully read these instructions before installing this gas burner system. Be sure you understand all safety precautions and warnings contained in this manual.
- A. BE CAREFUL:** If not installed, serviced, and used correctly per these instructions, this product can cause serious personal injury, property damage, or loss of life.
 - B. WARNING:** Before installing in a solid-fuel-burning fireplace, the chimney flue, damper, and firebox must be thoroughly CLEANED of soot, creosote, ashes, and loose paint, and must be inspected by a qualified chimney cleaner. Some older fireplaces may need repair prior to installing this appliance.
 - C.** This appliance is only for use with the type of gas indicated on the rating plate. This appliance is **NOT FIELD CONVERTIBLE** for use with other gasses.
CHECK GAS TYPE (natural or L.P.): The gas supply must be the same as stated on your burner system rating plate. If gas supply is different, **DO NOT INSTALL**. Contact your dealer for immediate assistance.
 - D. INSUFFICIENT GAS PRESSURE WILL KEEP THE PILOT (IF EQUIPPED) FROM OPERATING PROPERLY. DO NOT USE IF GAS PRESSURE IS LOWER THAN THE MINIMUM REQUIREMENT.**
 - E.** The *minimum* inlet gas-supply pressure for purposes of input adjustment is **5"** water column (w.c.) on **natural gas** and **11"** w.c. on **L.P. gas**. Insufficient gas pressure will affect proper operation of the pilot (if equipped). Do not install this gas appliance if minimum pressure is not available. The *maximum* inlet gas-supply pressure is **10.5"** w.c. on natural gas and **13"** w.c. on L.P. gas. The L.P. source must be regulated. **(Do not connect this appliance directly to an unregulated L.P. gas tank - this can cause an explosion.) Do not connect this appliance to a portable L.P. gas cylinder.**
 - F. The gas piping system must be sized to provide minimum inlet pressure at the maximum flow rate (BTU/hr).** Undue pressure loss will occur if the pipe is too small, or the run is too long. Gas supply pipe must be 1/2" minimum interior diameter. If the gas line is longer than 20', a larger diameter line may be necessary. Refer to the NFPA 54 guidelines for further details.
 - G.** Input ratings shown in BTU per hour are for elevations up to 2,000 ft. For elevations above 2,000 ft., refer to the National Fuel Gas Code or contact manufacturer before installing this product.
 - H.** This gas appliance and its main gas valve must be disconnected from the gas-supply piping system during any pressure testing of that system at test pressures in excess of 1/2 psig.
 - I.** This gas appliance must be isolated from the gas-supply piping system by closing the equipment shutoff valve connected to the gas-supply line during any pressure testing of the gas-supply piping system at test pressures equal to or less than 1/2 psig.
 - J. To install the gas appliance in your fireplace, the fireplace MUST meet the minimum size requirements.**
 - K.** This appliance may be installed in an aftermarket, permanently located, manufactured (mobile) home, where not prohibited by local codes. Installation of appliances designed for manufactured home (U.S. only) or mobile home installation must conform with the Standard *CAN/CSA Z240 MH, Mobile Housing*, in Canada, or with the *Manufactured Home Construction and Safety Standard, Title 24 CFR, Part 3280*, in the United States, or when such a standard is not applicable, *ANSI/NCSBCS A225.1/NFPA 501A, Manufactured Home Installations Standard*.
 - L. DO NOT install this burner system if the fireplace hearth is recessed.** The fireplace floor must be at the same level as or higher than the fireplace front opening. If glass doors are used: the fireplace floor must not be blocked by the door frame; the frame must have openings to allow for fresh air circulation.

L'INFORMATION DE SÛRETÉ IMPORTANTE DE PRÉINSTALLATION ET DE CHEMINÉE

- ATTENTION:** L'installation et la réparation doivent être faites par un NFI certifié ou tout autre installateur professionnel qualifié.
- Installateur:** Lisez soigneusement ces instructions avant d'installer ce système de brûleur à gaz. Soyez sûr que vous comprenez tous les mesures de sécurité et avertissements contenus en ce manuel.
- A. FAITES ATTENTION: Sinon installé, entretenu, et utilisé correctement par ces instructions, ce produit peut causer le dommage corporel, les dégâts matériels, ou les pertes humaines sérieux.**
- B. AVERTISSEMENT:** Avant l'installation dans une cheminée plein-carburant-brûlante, la conduite de cheminée, l'amortisseur, et le foyer de cheminée doivent ÊTRE COMPLÈTEMENT NETTOYÉS de la suie, de la créosote, des cendres, et de la peinture lâche, et doivent être inspectés par un décapant qualifié de cheminée. Quelques cheminées plus anciennes peuvent ont besoin de réparation avant d'installer cet appareil.
- C.** Cet appareil sert seulement avec le type de gaz indiqué de la plaque de contrôle. Cet appareil n'est pas CONVERTIBLE de CHAMP pour l'usage avec d'autres gaz.
VÉRIFIEZ LE TYPE de GAZ (normal ou propane) : La fourniture de gaz doit être identique qu'indiquée de votre plaque de contrôle de système de brûleur. Si la fourniture de gaz est différente, **N'INSTALLEZ PAS**. Contactez votre revendeur pour l'aide immédiate.
- D.** LA PRESSION DE GAZ INSUFFISANTE GARDERA LE PILOTE DU FONCTIONNEMENT CORRECTEMENT (SI ÉQUIPÉ). N'EMPLOYEZ PAS SI LA PRESSION DE GAZ EST INFÉRIEURE À LA CONDITION MINIMUM.
- E.** L'admission minimum gaz-fournissent la pression aux fins de l'ajustement d'entrée est 5" ; colonne d'eau (w.c.) sur le gaz naturel et le 11" ; w.c. sur le gaz de propane. La pression de gaz insuffisante affectera l'opération appropriée du pilote (si équipé). N'installez pas cet appareil à gaz si la pression minimum n'est pas disponible. L'admission maximum gaz-fournissent la pression est 10.5" ; w.c. sur le gaz naturel et le 13" ; w.c. sur le gaz de propane. La source de propane doit être réglée. **(Ne branchez pas cet appareil directement à un réservoir de gaz propane non réglementée - cela peut provoquer une explosion.) Ne branchez pas cet appareil à une bouteille de gaz propane portable.**
- F.** **Le système sifflant de gaz doit être classé pour fournir la pression d'admission minimum au débit maximum (BTU/hr).** La perte de pression anormale se produira si la pipe est trop petite, ou la course est trop longue. La pipe de fourniture de gaz doit être 1/2" ; diamètre intérieur minimum. Si la ligne de gaz est plus longue que 20' ; une ligne de plus grand diamètre peut être nécessaire. Reportez-vous aux directives NFPA 54 pour plus de détails.
- G.** Les estimations d'entrée montrées en Btu par heure sont pour des altitudes jusqu'à 2.000 pi. Pour des altitudes au-dessus de 2.000 pi, référez-vous au code national de gaz de carburant ou entrez en contact avec le fabricant avant d'installer ce produit.
- H.** Cet appareil à gaz et son clapet à gaz principal doivent être disconnected du gaz-fournissent le système sifflant pendant tout vérificateur de pression de ce système aux pressions d'essai au-dessus de 1/2 psig.
- I.** Cet appareil à gaz doit être isolé dans gaz-fournissent le système sifflant en fermant le robinet d'isolement d'équipement relié au gaz-fournissent la ligne pendant tout vérificateur de pression du gaz-fournissent le système sifflant aux pressions d'essai égales à ou moins d'à 1/2 psig.
- J. Pour installer l'appareil à gaz dans votre foyer, le foyer doit satisfaire aux exigences minimales de taille.**
- K.** Cet appareil peut être installé dans un marché des accessoires, maison (mobile) de manière permanente située et manufacturée, où non interdit par des codes locaux. L'installation des appareils a conçu pour la maison manufacturée (États-Unis seulement) ou installation de caravane résidentielle doit se conformer au CAN/CSA standard Z240 MH, logement mobile, au Canada, ou à la construction et au standard de sécurité à la maison manufacturés, intitulent 24 CFR, la partie 3280, aux Etats-Unis, ou quand une telle norme ne s'applique pas, à ANSI/NCSBCS A225.1/NFPA 501A, installations à la maison manufacturées standard.
- L. NE PAS installer ce système de brûleur si le foyer de la cheminée est en retrait.** Le plancher du foyer doit être au même niveau ou plus élevé que l'ouverture de cheminée avant. Si les portes en verre sont utilisées: le plancher du foyer ne doit pas être bloqué par le cadre de la porte; le cadre doit avoir des ouvertures pour permettre la circulation de l'air frais.

FIREPLACE OPERATING SAFETY INFORMATION

- A. Adults shall be present when this gas appliance is operating. This unit shall not be left burning when unattended or while anyone is sleeping.
- B. Keep the area of the gas burner system clear and free from combustible materials, gasoline, and other flammable vapors and liquids.
- C. DO NOT use this appliance if any part has been underwater. Immediately call a qualified service technician to inspect the appliance and to replace any part of the control system and any gas control that has been underwater. Attempted operation may result in fire or explosion resulting in property damage, personal injury or loss of life.
- D. **A fireplace screen must be in place when the system is burning.** Provisions for adequate combustion air must be maintained. Unless other provisions for combustion air are provided, the screen shall have an opening(s) for introduction of combustion air. Combustion air is adequate when all flames curl into the fireplace and away from the screen. **When a glass fireplace enclosure (door) is used, leave the doors fully open when the system is in operation.**
- E. Do not remove the rating plates or the warning tags. These are an integral safety and identification component of this appliance.

INFORMATIONS SUR LA SÉCURITÉ D'EXPLOITATION DE CHEMINÉE

- A. Adultes doivent être présents lors de cet appareil au gaz est en marche. Cette unité ne doit pas être laissé sans surveillance ou brûlure lorsque tout quelqu'un dort.
- B. Gardez le domaine du clair réglé de notation de gaz et libérez des matériaux combustibles, l'essence, et d'autres vapeurs et liquides inflammables.
- C. Ne pas utiliser cet appareil si une partie quelconque a été submergée. Appelez immédiatement un technicien de service qualifié pour inspecter l'appareil et pour remplacer toute pièce du système de contrôle et toute commande de gaz qui a été sous l'eau. Tentative d'opération peut entraîner un incendie ou une explosion entraînant des dommages matériels, des blessures ou des pertes de vie.
- D. **Una pantalla de la chimenea debe ser en el lugar cuando el sistema está quemando.** Las provisiones para el aire de combustión adecuado deben ser mantenidas. A menos que otras provisiones para el aire de combustión se proporcionen, la pantalla tendrá una abertura para la introducción de aire de combustión. El aire de combustión es adecuado cuando todas las llamas se encrespan en la chimenea y lejos de la pantalla. **Cuando se utiliza un recinto de cristal de la chimenea (puerta), deje las puertas completamente abiertas cuando el sistema es en funcionamiento.**
- E. Ne retirez pas les plaques signalétiques ou les étiquettes d'avertissement. Ceux-ci sont une composante de sécurité et d'identification intégrante de cet appareil.

GLASS / GEMS QUANTITY DETERMINATION

CAUTION: Sand is used with natural gas systems only. Always use vermiculite for propane gas systems.

The sand/vermiculite that come with the burner system are pre-measured and must be used per these instructions (see GLASS / GEMS PLACEMENT section).

Decorative glass / gems (purchased separately) must be placed to cover the burner (but not on the valve or pilot, if equipped). See Table 13-1 for the minimum bag requirement depending on your burner size. Additional glass / gems may be purchased and placed around the burner if desired.

Should you wish to fill the entire fireplace floor with glass / gems; instead use Table 13-2 to determine how many bags of glass / gems to order **based on fireplace size**.

One 10-lb. bag of glass / gems fills approximately 144 cubic inches.

CAUTION: When covering the burner with glass / gems; do not exceed 1" above the top of the burner. Additional glass / gems directly on top of the burner may result in unsafe ignition.

Minimum burner coverage requirement Table 13-1	Burner size		
	18	24	30
Glass / gem 10 lb. bag(s) needed	1	1	1

- OR -

Fireplace complete coverage Table 13-2	Fireplace				Glass / gems 10 lb. bags needed for 2" depth
	Opening size	Center width (in.)	Front to back depth (in.)	Area (sq. in.)	
Standard Fireplace Sizes	28"	25	16	400	6
				540	8
	36"	30	23	690	10
	32" see-thru	31	23	713	10
	42"	36	30	828	12
				1085	15
	50"	46	33	1334	19

These bag quantities listed allow for an approximate 2" depth of glass / gems in the entire fireplace floor, without a burner. (The volume of the burner will take up some space, allowing for some excess glass to be used as desired, or stored as extra for later use.)

Your fireplace area can be determined by measuring the center width of your fireplace in inches and multiplying by the depth from front to back in inches. You can then use the area column in the table above to approximate the number of bags needed.

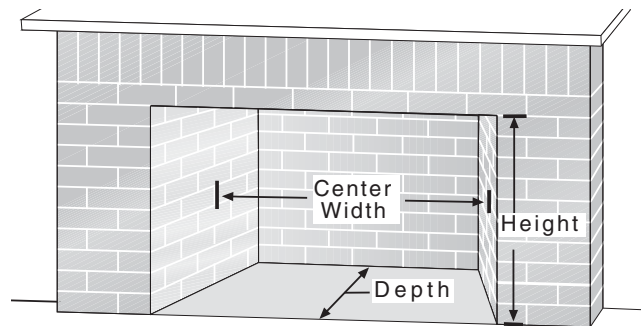

INSTALLATION

The damper clamp with hex bolt (Fig. 14-1) is provided as a means to prevent full closure of the damper blade. The clamp is easily attached to most damper blades with pliers or a wrench, and must be permanently installed. The clamp is designed to prevent accidental closure of the damper when installed as illustrated (Fig. 14-2 and Fig. 14-3). Should the clamp not fit, or fail to provide the permanent vent opening listed in the table found above, have a permanent stop installed, remove the damper blade, or have the damper cut to provide the minimum permanent opening required.

Note: These are minimum damper opening specifications. The damper must be completely opened when operating this gas appliance to achieve the best ventilation possible.

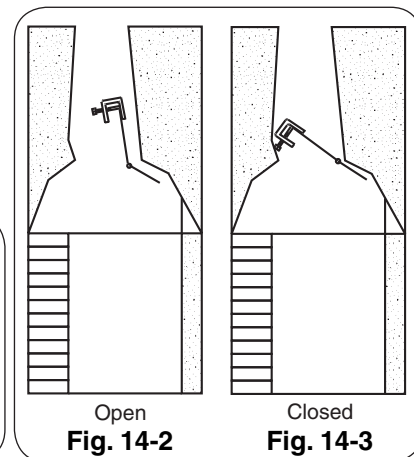
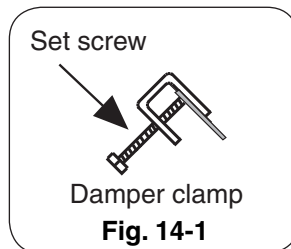

INSTALLING THE BURNER

The Real Fyre gas burner system must be installed by a qualified professional service technician. Instructions must be followed carefully to ensure proper performance and full benefit from the gas burner system. **Check to be sure the burner system is designed and labeled for the type of gas (natural or propane gas) supplied to the fireplace. Fireplace floor must be level, clean, and smooth.**

WARNING: Failure to position the parts in accordance with these diagrams or failure to use only parts specifically approved with this appliance may result in property damage or personal injury.

REFER TO THE PARTS LIST WHEN FOLLOWING THESE INSTRUCTIONS.

1. MAKE SURE THE FIREPLACE GAS SUPPLY IS TURNED OFF.
2. Locate the gas-supply stub inside the fireplace and remove the cap, if attached (see Fig. 14-4).

CAUTION: When removing the cap, make sure the stub does not turn, loosening the connection inside the wall.

3. Attach the nut end of the flex connector (Item 4) to the adapter found on the valve or, if attached, on the regulator behind the valve. Tighten securely.
4. Place the burner system into the fireplace so that it is centered.
5. **Be sure gas to the fireplace is off.** Attach the large adapter end of the flex connector (Item 4) to the gas-supply stub using a pipe compound resistant to all gases. Ensure adapter (and nut) are tightened securely. Ensure the pan rests level on the fireplace floor after connection. Adjust the pan if necessary.
6. **LEAK TEST:** Turn on the fireplace gas supply, and test at all connections for leaks using the appropriate soapy water solution. If bubbles appear, a leak is present. Turn off the gas and tighten at all connections. Repeat until no leaks are present. If a leak persists, turn off the gas supply and contact the local gas company or dealer. **NEVER USE A FLAME TO CHECK FOR LEAKS.**

Turn off the gas supply prior to proceeding.

7. Place the heat shield over the regulator and/or valve.

Important: Heat shields must be in place during operation of the gas burner system. Overheating of the valve will cause shut down of the gas burner system or other operating problems.

8. If this unit was shipped with a remote, read and follow the separate remote instructions (packed with remote) for complete remote installation.

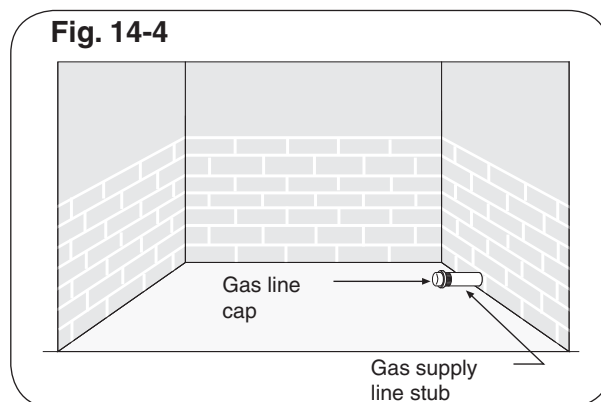

01 VALVE MODELS ONLY

CONNECTING THE IGNITION PACK TO THE VALVE

The 01 valve comes complete with the wiring harness connected to the switch box. You may wish to ensure it is correctly connected before finally connecting the three wires to the valve, as below.

TO CHECK THE WIRING ASSEMBLY:

- Check that the wiring harness is fitted tightly into the connector on the green igniter pack inside the switch box (Fig. 15-1).
- Check that the female connectors on the two black wires from the pilot assembly (wires marked "I" and "S") are inserted fully into the male connectors on the igniter pack (Fig. 15-2).
- Check the connection of the red and black wires of the wire harness to the respective counterpart wires from the battery holder (red-red and black-black). The two brown wires should be connected to the switch.

Note: The two spare brown wires with coated male connectors are used to connect a remote system (if equipped).

- Connect the wires to the valve in the following order (see Fig. 15-2):

Orange wire marked THTP - to THTP connector on valve

Black wire marked TP - to TP connector on valve

Green wire marked TH - to TH connector on valve

The diagram below shows the wiring layout for the complete unit.

INSTALLING OR REPLACING BATTERIES FOR IGNITION MODULE PACK

Two 1.5-volt (D-cell) alkaline batteries are supplied with the burner system. To install or replace batteries, remove any old batteries (if applicable) and install new batteries according to the diagram illustrated on the battery holder mounted inside the switch box (Fig. 15-3).

Note: For the system to work properly, it is suggested that you replace the batteries annually with fresh batteries. Always replace all the batteries at the same time.

SWITCH BOX PLACEMENT

Place the switch box outside of the firebox and a minimum of 6" from the burner/flame. If the switch box is in the firebox, the switch box must only be oriented as shown in Fig. 15-4. The switch box must not be placed in the rear of the fireplace, or in any other manner than shown in Fig. 15-4. Set the box on its side and place the bottom of the box toward the right firebox wall (box must be a minimum of 6" from the burner/flame). Be sure that the pilot and valve wire bundles remain clear of the burner, valve, and heat shield at all times.

Note: Coil excess wire within the switch box.

CAUTION: THE SWITCH BOX MAY BE HOT DURING AND AFTER OPERATION.

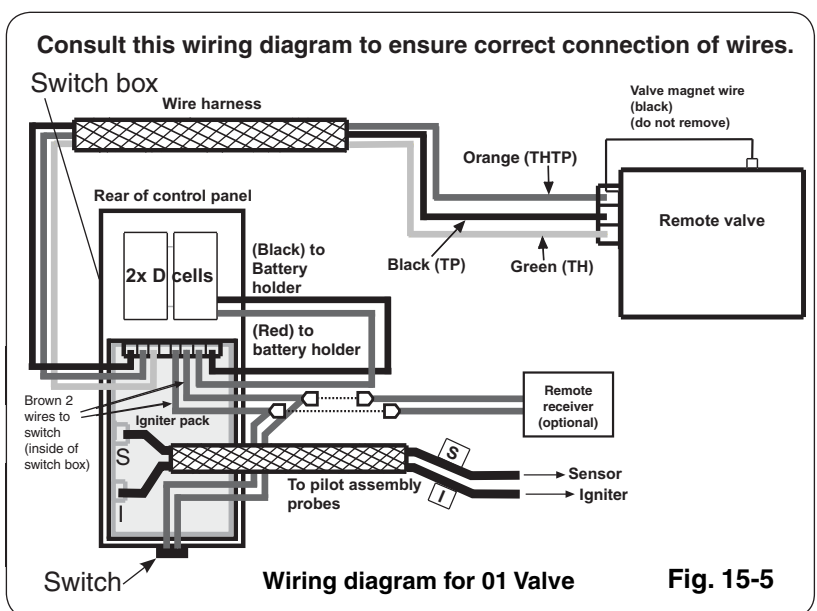
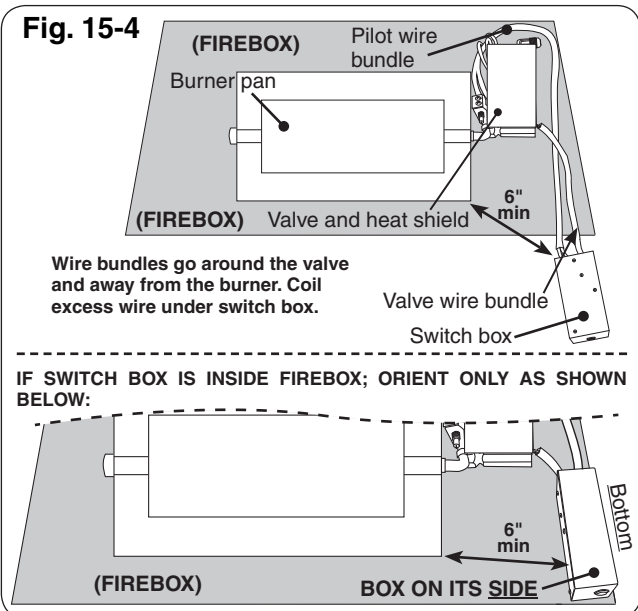
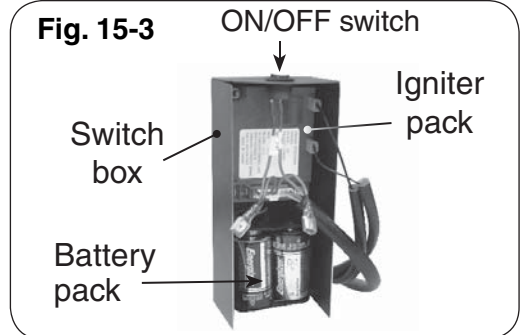
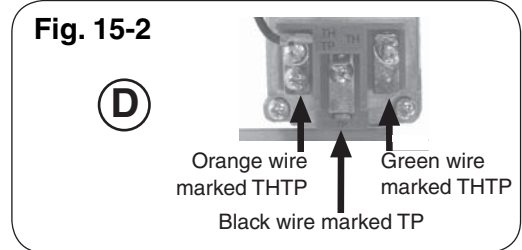
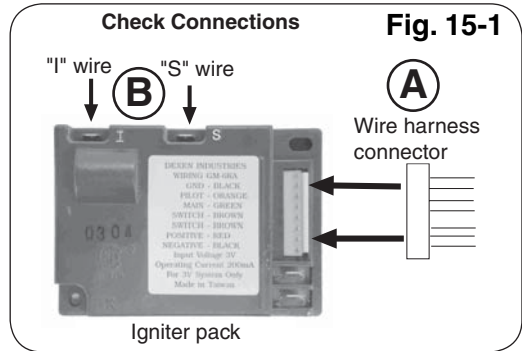

Please use this page to record any information that you may want to have at hand.

GLASS / GEMS PLACEMENT

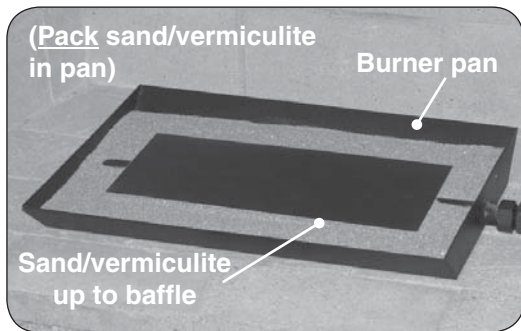

Fig. 17-1

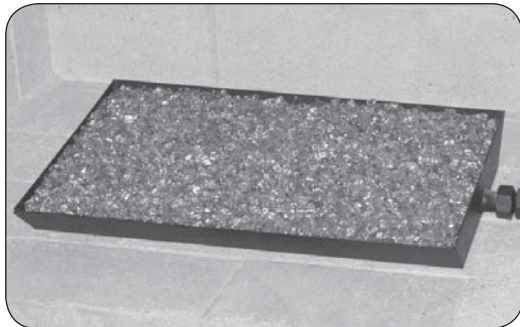

Fig. 17-2



Fig. 17-3

BURNER PREPARATION

After hooking up the burner to the fireplace gas supply and placing the heat shield on the valve assembly (if applicable), the decorative media (sand/vermiculite and glass/gems) must be added for the burner to function as designed.

Note: Installation is the same for glass and gems. Glass shown here. These instructions show sand being used as a base for the glass, but only natural-gas burners use sand. For propane burners, follow these instructions using vermiculite.

WARNING

The burner and pilot (if equipped) must be **OFF** (fully extinguished), and all valve covers must be in place before pouring media onto the burner. It may also be necessary to temporarily cover the pilot assembly (if equipped) to keep media out of it during this procedure.

SAND/VERMICULITE PLACEMENT

Pour the sand/vermiculite into the pan, just below level of the center flame baffle. Then pack the sand/vermiculite into the pan. Add additional sand/vermiculite as needed (see Fig. 17-1).

GLASS / GEMS PLACEMENT

CAUTION: Glass pieces may have sharp edges. Be careful handling the glass. Use hand protection, such as gloves, if necessary.

1. Pour the glass / gems directly on top of the burner pan so that the burner pan is covered completely and evenly (see Fig. 17-2). DO NOT exceed a 1" depth of glass directly above the burner pan.

Note: At this stage the burner will function as designed; however, more glass / gems may be added around the burner for decorative purposes.

2. Add additional glass / gems around the burner pan as desired (Fig. 17-3).

INSTRUCTIONS D'ÉCLAIRAGE - PILOTE ET VALVE MANUELS DE LA SÉRIE 17

POUR VOTRE SÛRETÉ, LISEZ AVANT DE S'ALLUMER

AVERTISSEMENT: Si vous ne suivez pas ces instructions exactement, un incendie ou une explosion peut résulter entraînant des dégâts matériels, des blessures ou la perte de la vie.

N'employez pas cet appareil si n'importe quelle partie a été sous-marine. Réclamez immédiatement un technicien de service professionnel qualifié et pour inspecter l'appareil et pour remplacer n'importe quelle partie du système de commande et de n'importe quelle commande de gaz qui a été sous l'eau.

Le Real Fyre système de brûleur a un pilote qui peut être allumé à la main en utilisant une allumette ou un allumeur. En allumant le pilote, suivez ces instructions exactement.

AVANT DE S'ALLUMER, sentez tous autour du secteur de brûleur pour le gaz. Soyez sûr de sentir à côté du plancher car un certain gaz est plus lourd que l'air et arrangez sur le plancher. SI VOUS SENTEZ LE GAZ, SUIVEZ LES INSTRUCTIONS À LA P. 1.

Utilisez seulement votre main pour enfoncer ou pour tourner le bouton de commande de gaz. N'utilisez jamais les outils. Si le bouton n'enfoncera pas ou ne tournera pas à la main, n'essayez pas de le réparer. Appelez un technicien de service professionnel qualifié et. La force ou la réparation essayée peut avoir comme conséquence l'incendie ou l'explosion.

ALLUMER LE PILOTE

1. Si le bouton de soupape de commande de brûleur n'est pas dans la position de **OFF**, enfoncez la poignée de commande de gaz légèrement et tournez-vous dans le sens des aiguilles d'une montre  vers **OFF** (fig. 18-1).

Note: Le bouton de commande de brûleur ne peut pas être tourné du **PILOT** au **OFF** à moins que la poignée soit enfoncée légèrement. Ne forcez pas.

Attendez cinq minutes pour dégager dehors n'importe quel gaz. Si vous sentez alors le gaz, **ARRÊTEZ!** Informez votre fournisseur de gaz ou le département de feu immédiatement. Si vous ne sentez pas le gaz, passez dessus à l'étape 2.

2. Tournez le bouton de commande de brûleur dans le sens contraire des aiguilles d'une montre  au **PILOT** (fig. 18-1). Poussez la poignée de commande toute la manière dedans et tenez-la. Tenez une longue allumette de cheminée ou un proche plus léger le thermocouple pour allumer le pilote. Continuez à tenir le bouton de commande pour approximativement 30 secondes après que le pilote est allumé pour permettre au thermocouple de détecter la flamme pilote, puis libérez le bouton. Le pilote restera s'est allumé.

- Si le pilote ne s'allumera pas, répétez les étapes 1. et 2.
- Si le pilote ne restera pas s'allumait après que plusieurs essais, tournent la poignée de commande de gaz à **OFF** et appellent votre fournisseur de technicien ou de gaz de service.

ALLUMAGE DU BRÛLEUR PRINCIPAL

1. Assurez-vous que le pilote brûle.
2. Tournez la poignée de commande de gaz dans le sens contraire des aiguilles d'une montre  à **ON** (fig. 18-1) pour mettre à feu le brûleur. Le brûleur mettra à feu.

Note: Examinez périodiquement la flamme pilote pour assurer le modèle approprié de flamme (Fig. 18-1).

ASSUREZ-VOUS QUE LE THERMOCOUPLE ET L'ASSEMBLÉE PILOTE SONT EN ALIGNEMENT CORRECT AVEC L'UN L'AUTRE (FIG. 18-1).

ROTATION OUTRE DU BRÛLEUR PRINCIPAL

1. De la position de **ON**, tournez le bouton de commande dans le sens des aiguilles d'une montre  à la position **PILOT**. Le brûleur s'éteindra et le pilote restera s'est allumé.

S'ÉTEINDRE LE PILOTE

1. Si complet l'arrêt est désiré, de la position **PILOT**, de l'enfoncer le bouton de commande légèrement et du tour dans le sens des aiguilles d'une montre  à la position de repos. Ne forcez pas le bouton. **NE FORCEZ PAS LE BOUTON.** Ceci exigera du pilote d'être re-s'est allumé avant d'utiliser le brûleur encore.

Le SPK-17 est capable de l'éclairage à distance. Si votre unité est équipée d'un extérieur, lisez et suivez les instructions à distance séparées d'actionner le brûleur à distance.

(valve manuelle montrée)



1. S'ALLUMER - tournez le bouton de commande de brûleur à **OFF**  et attendez 5 minutes avant de s'allumer.

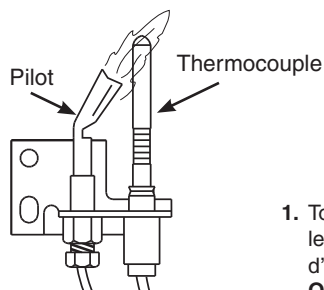
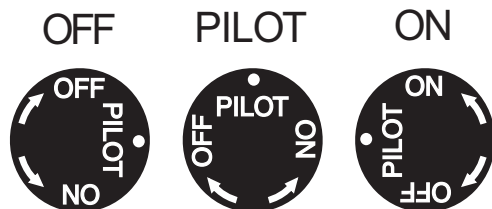



Fig. 18-1



1. Tournez le cadran dans le sens des aiguilles d'une montre  à **OFF** seulement quand l'arrêt complet est nécessaire.
2. Tournez le cadran dans le sens contraire des aiguilles d'une montre  à la position **PILOT**. Avec le bouton prêt de pression d'allumette dedans et la prise pendant 60 secondes tout en allumant le pilote.
3. Tournez le bouton contre- dans le sens des aiguilles d'une montre à **ON** au brûleur léger.

LIGHTING INSTRUCTIONS - MANUAL PILOT AND SERIES 17 VALVE

FOR YOUR SAFETY, READ BEFORE LIGHTING

WARNING

If you do not follow these instructions exactly, a fire or explosion may result, causing property damage, personal injury, or loss of life.

Do not use this appliance if any part has been underwater. Immediately call for a qualified professional service technician to inspect the appliance and to replace any part of the control system and any gas control that has been underwater.

The Real Fyre burner system has a pilot that can be lit by hand using a match or lighter. When lighting the pilot, follow these instructions exactly.

BEFORE LIGHTING, smell all around the burner area for gas. Be sure to smell next to the floor, as some gas is heavier than air and will settle on the floor. IF YOU SMELL GAS, FOLLOW THE INSTRUCTIONS ON P. 1.

Use only your hand to push in or turn the gas control knob. Never use tools. If the knob will not push in or turn by hand, don't try to repair it. Call a qualified professional service technician. Excessive force or attempted repair may result in fire or explosion.

LIGHTING THE PILOT

1. Push in the gas control knob slightly and turn clockwise ↻ to **OFF** (Fig. 19-1). Refer to the PARTS LIST for the location of the burner control valve knob.

Note: The burner control knob cannot be turned from **PILOT** to **OFF** unless the knob is pushed in slightly. Do not force.

Wait five minutes to clear out any gas. If you then smell gas, STOP! Notify your gas supplier or the fire department immediately. If you don't smell gas, go on to step 2.

2. Turn the burner control knob counter-clockwise ↺ to **PILOT** (Fig. 19-1). Push the control knob **firmly and fully** in and hold. Hold a long fireplace match or lighter near the thermocouple to light the pilot. Continue to hold the control knob in for approximately 30 seconds after the pilot is lit, then release the knob. The pilot will remain lit.
- If the pilot will not light, repeat steps 1 and 2.
 - If the pilot will not stay lit after several tries, turn the gas control knob to **OFF** and call your service technician or gas supplier.

IGNITING THE MAIN BURNER

1. Make sure the pilot is burning.
2. Turn the gas control knob counterclockwise ↺ to **ON** (Fig. 19-1) to ignite the burner. The burner will ignite.

Note: Periodically check the pilot flame for the proper flame pattern (Fig. 19-1).

MAKE SURE THE THERMOCOUPLE AND PILOT ASSEMBLY ARE IN CORRECT ALIGNMENT WITH EACH OTHER (Fig. 19-1).

TURNING OFF THE MAIN BURNER

1. From the **ON** position, turn the control knob clockwise ↻ to the **PILOT** position. The burner will extinguish, and the pilot will remain lit.

EXTINGUISHING THE PILOT

1. If complete shutdown is desired, from the **PILOT** position, push in the control knob slightly and turn clockwise ↻ to the **OFF** position. **Do not force the knob.** This will require the pilot to be relit before using the burner again.

The series 17 valve is capable of remote operation. **If this unit was shipped with a remote, or if a remote system was installed later, read and follow the separate remote instructions to operate the burner remotely.**

(Manual valve shown)



1. Lighting - Turn the burner control knob to **OFF** ↻ and wait 5 minutes before lighting.

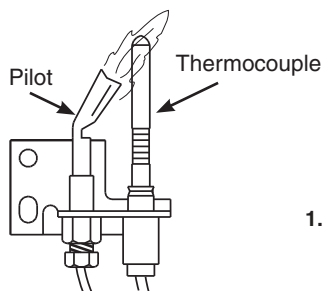

Pilot Assembly
Fig. 19-1

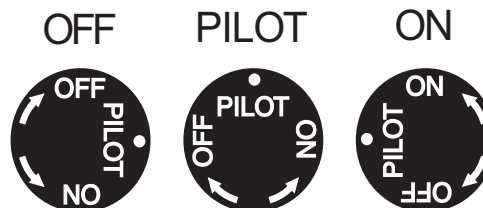

1. Turn the knob clockwise ↻ to **OFF** only when complete shutdown is desired or prior to lighting the pilot.
2. Turn knob counterclockwise ↺ to **PILOT** position. With match ready, press knob in and hold for 60 seconds while lighting pilot.
3. Turn the knob counterclockwise ↺ to **ON** to light the burner.

INSTRUCTIONS D'ÉCLAIRAGE - VALVE DE LA SÉRIE 11

POUR VOTRE SÛRETÉ, LISEZ AVANT DE S'ALLUMER

AVERTISSEMENT : Si vous ne suivez pas ces instructions exactement, un incendie ou une explosion peut résulter entraînant des dégâts matériels, des blessures ou la perte de la vie.

N'employez pas cet appareil si n'importe quelle partie a été sous-marine. Réclamez immédiatement un technicien de service professionnel qualifié et pour inspecter l'appareil et pour remplacer n'importe quelle partie du système de commande et de n'importe quelle commande de gaz qui a été sous l'eau.

Le Real Fyre système de brûleur a un pilote qui peut être allumé à la main en utilisant une allumette ou un allumeur. En allumant le pilote, suivez ces instructions exactement.

AVANT DE S'ALLUMER, sentez tous autour du secteur de brûleur pour le gaz. Soyez sûr de sentir à côté du plancher car un certain gaz est plus lourd que l'air et arrangez sur le plancher. SI VOUS SENTEZ LE GAZ, SUIVEZ LES INSTRUCTIONS À LA P. 1.

Utilisez seulement votre main pour enfoncer ou pour tourner le bouton de commande de gaz. N'utilisez jamais les outils. Si le bouton n'enfoncera pas ou ne tournera pas à la main, n'essayez pas de le réparer. Appelez un technicien de service professionnel qualifié et. La force ou la réparation essayée peut avoir comme conséquence l'incendie ou l'explosion.

ALLUMANT LE PILOTE

Pour lire le bouton de commande de soupape de sûreté (Fig. 20-1) lisez l'indicateur formé par l'anneau la plus proche en métal d'inscription.

1. Si le bouton de commande de soupape de sûreté est en position **PILOT**, enfoncez légèrement sur le bouton et tournez-le dans le sens des aiguilles d'une montre jusqu'à la position de **OFF**.
2. Libérez le bouton et attendez cinq minutes.
3. Tournez le bouton de soupape de sûreté dans le sens contraire des aiguilles d'une montre à la position **PILOT** (seulement le gaz pilote coulera quand le bouton est enfoncé).
4. Placez une longue allumette ou un allumeur de butane au brûleur pilote et en même temps, poussez le bouton de soupape de sûreté entièrement dedans. Le pilote s'allumera.
5. Tenez le bouton de soupape de sûreté dedans pendant approximativement 60 secondes avant de libérer.
6. Si le pilote ne reste pas s'allumait, la position de **OFF** de bouton de soupape de sûreté dans le sens des aiguilles d'une montre entièrement. Attendez cinq minutes, puis répétez les étapes 3. à 5.

METTANT À FEU LE BRÛLEUR PRINCIPAL

Avec lampe témoin, tournez le bouton de soupape de sûreté dans le sens contraire des aiguilles d'une montre à la position de **ON**. Commutez la commande d'interrupteur à levier à la position de **ON** et le brûleur s'allumera.

COUPANT LE BRÛLEUR PRINCIPAL

Commutez la commande d'interrupteur à levier à la position de **OFF**. Le pilote restera s'est allumé.

COUPANT LE PILOTE

Soyez sûr que commande d'interrupteur à levier est éteint et enfonce et tourne le bouton de soupape de sûreté dans le sens des aiguilles d'une montre à la position de **OFF**.

AJUSTANT LE PILOTE

1. La flamme pilote devrait encercler le bout de générateur, et est préréglée à l'usine (Fig. 20-2).
2. Si l'ajustement est nécessaire, (Fig. 20-1) tournez la vis d'approche de gaz dans le sens contraire des aiguilles d'une montre pour augmenter la flamme pilote, ou pour diminuer dans le sens des aiguilles d'une montre la flamme pilote.

ENTRETIEN

Votre brûleur à casserole est équipé d'un pilote de sûreté qui coupera l'offre de gaz au cas où le pilote serait ne brûlant pas ou ne fonctionnant pas correctement. Assurez-vous que le pilote est ajusté correctement et que les agrafes de cosse de générateur sont étroitement reliées aux vis terminales sur la valve. Si le pilote ne restera pas allumait, appelle votre utilité de gaz ou fournisseur locale de gaz.

Un contrôle périodique du suivant devrait être exécuté au moins annuellement par un représentant qualifié de service professionnel.

1. Valves et commande d'interrupteur à levier pour l'opération appropriée.
2. Système de conduite de cheminée pour la rouille, les dommages ou les fuites.
3. Une opération plus humide.
4. Orifices pour la saleté ou d'autres corps étrangers.
5. Contrôle visuel sur le brûleur.

Si cette unité était embarquée avec un extérieur, ou si un système à distance était installé plus tard, lisez et suivez les instructions à distance séparées d'actionner le brûleur à distance.

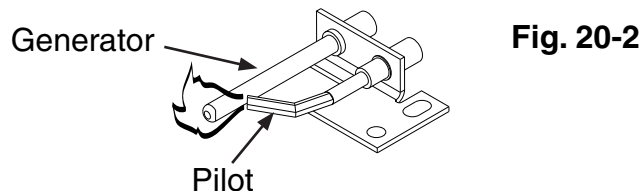
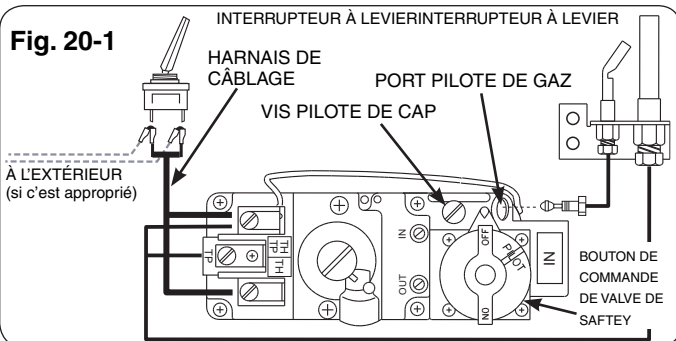

Note: La flamme pilote devrait encercler le dessus du générateur

LIGHTING INSTRUCTIONS - SERIES 11 VALVE

FOR YOUR SAFETY, READ BEFORE LIGHTING

WARNING

If you do not follow these instructions exactly, a fire or explosion may result, causing property damage, personal injury, or loss of life.

Do not use this appliance if any part has been underwater. Immediately call for a qualified professional service technician to inspect the appliance and to replace any part of the control system and any gas control that has been underwater.

The Real Fyre burner system has a pilot that can be lit by hand using a match or lighter. When lighting the pilot, follow these instructions exactly.

BEFORE LIGHTING, smell all around the burner area for gas. Be sure to smell next to the floor, as some gas is heavier than air and will settle on the floor. **IF YOU SMELL GAS, FOLLOW THE INSTRUCTIONS ON P. 1.**

Use only your hand to push in or turn the gas control knob. Never use tools. If the knob will not push in or turn by hand, don't try to repair it. Call a qualified professional service technician. Force or attempted repair may result in fire or explosion.

LIGHTING THE PILOT

To read the safety valve control knob (Fig. 21-1), read the marking nearest the teardrop-shaped metal pointer.

1. If the safety valve control knob is in the **PILOT** position, push in slightly on the knob and rotate it clockwise ↻ to the **OFF** position.
2. Release knob and wait five (5) minutes.
3. Turn safety valve knob counterclockwise ↺ to the **PILOT** position. (Only the pilot gas will flow when the knob is pushed in.)
4. Place a long match or a butane lighter at the pilot burner, and at the same time, push the safety valve knob fully in. The pilot will light.
5. Hold the safety valve knob in for approximately 60 seconds before releasing.
6. **If the pilot does not stay lit**, turn the safety valve knob clockwise ↻ to the full **OFF** position. Wait five (5) minutes, then repeat steps 3 through 5.

IGNITING THE MAIN BURNER

With the pilot lit, turn the safety valve knob counterclockwise ↺ to the **ON** position. Switch the toggle switch control to the **ON** position, and the burner will light. Refer to the PARTS LIST for the toggle switch location.

SHUTTING OFF THE MAIN BURNER

Switch the toggle switch control to the **OFF** position. The pilot will remain lit.

SHUTTING OFF THE PILOT

Be sure the toggle switch control is **OFF** and depress and turn the safety valve knob clockwise ↻ to the **OFF** position.

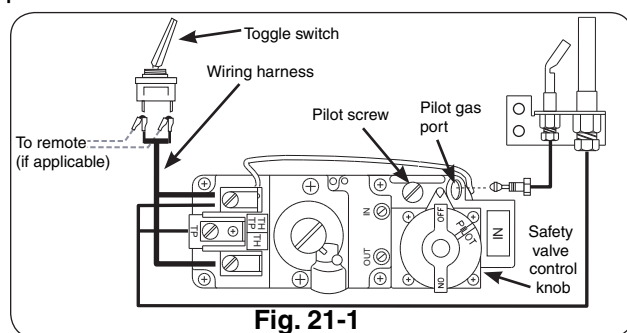

Fig. 21-1

ADJUSTING THE PILOT

- a. The pilot flame should encircle the generator tip, and is preset at the factory (Fig. 21-2).
- b. If adjustment is necessary (Fig. 21-1), turn the gas adjustment screw counterclockwise ↺ to increase the pilot flame, or clockwise ↻ to decrease the pilot flame.

MAINTENANCE

Your pan burner is equipped with a safety pilot that will shut off the gas supply in the event that the pilot is not functioning properly. Make sure the pilot is adjusted properly and that the generator spade clips are tightly connected to the terminal screws on the valve. If the pilot will not stay lit, call your local gas utility or gas supplier.

A periodic check of the following should be performed at least annually by a qualified professional service representative:

1. Valves and toggle switch control for proper operation.
2. Flue system for rust, damage, or leaks.
3. Damper operation.
4. Orifices for dirt or other foreign matter.
5. Visual check on the burner.

If this unit was shipped with a remote, or if a remote system was installed later, read and follow the separate remote instructions to operate the burner remotely.

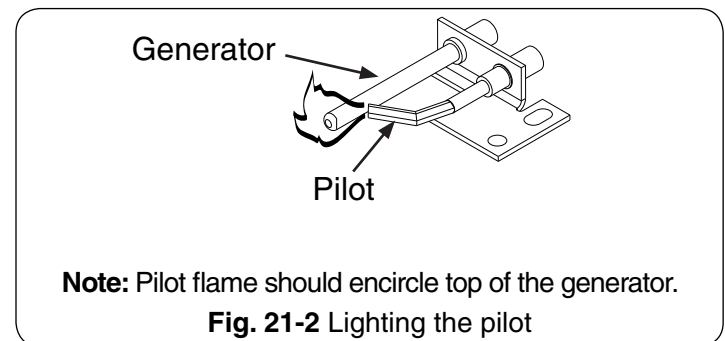

Note: Pilot flame should encircle top of the generator.

Fig. 21-2 Lighting the pilot

INSTRUCTIONS D'ÉCLAIRAGE - VALVE DE LA SÉRIE 15

POUR VOTRE SÛRETÉ, LISEZ AVANT DE S'ALLUMER

AVERTISSEMENT : Si vous ne suivez pas ces instructions exactement, un incendie ou une explosion peut résulter entraînant des dégâts matériels, des blessures ou la perte de la vie.

N'employez pas cet appareil si n'importe quelle partie a été sous-marine. Réclamez immédiatement un technicien de service professionnel qualifié et pour inspecter l'appareil et pour remplacer n'importe quelle partie du système de commande et de n'importe quelle commande de gaz qui a été sous l'eau.

Le Real Fyre système de brûleur a un pilote qui peut être allumé à la main en utilisant une allumette ou un allumeur. En allumant le pilote, suivez ces instructions exactement.

AVANT DE S'ALLUMER, sentez tous autour du secteur de brûleur pour le gaz. Soyez sûr de sentir à côté du plancher car un certain gaz est plus lourd que l'air et arrangez sur le plancher. **SI VOUS SENTEZ LE GAZ, SUIVEZ LES INSTRUCTIONS À LA P. 1.**

Utilisez seulement votre main pour enfoncer ou pour tourner le bouton de commande de gaz. N'utilisez jamais les outils. Si le bouton n'enfoncera pas ou ne tournera pas à la main, n'essayez pas de le réparer. Appelez un technicien de service professionnel qualifié et. La force ou la réparation essayée peut avoir comme conséquence l'incendie ou l'explosion.

ALLUMAGE DU PILOTE

1. Tourner le bouton de commande de l'allumage (Fig. 22-1) sur l'ensemble de soupape de commande de brûleur (le côté de la cuvette du brûleur) vers la gauche de sorte que la partie se rétrécissant de la poignée se déplace de la position **OFF**, légèrement vers l'**IGN**, jusqu'à atteindre la butée.
2. Appuyez sur le bouton de commande d'allumage et maintenez pendant cinq (5) secondes (uniquement du gaz pilote coulera).
3. Continuez à appuyer tout en tournant le bouton de commande d'allumage sens anti-horaire vers la position **PILOT** jusqu'à ce que vous entendiez un clic. Le clic est une indication que l'allumeur piézo a été activé.

Remarque: Si l'étincelle de l'allumeur piézo n'allume pas le pilote, répétez les étapes 2 et 3 jusqu'à ce que les voyants.

4. Maintenez le bouton de commande d'allumage en position **PILOT** pendant 60 secondes après que le pilote a été allumé pour permettre au thermocouple pour détecter la flamme de la veilleuse. Le pilote reste allumé. **Si le pilote ne s'allume pas après plusieurs essais, tournez le bouton de commande d'allumage sur OFF et contacter un technicien de service professionnel qualifié.**

ALLUMAGE LE BRÛLEUR PRINCIPAL

1. Lorsque la flamme pilote est stable, relâchez le bouton de commande d'allumage et tournez dans le sens antihoraire à la position **ON** pour activer le brûleur principal.
2. Tournez le bouton de contrôle de flamme de hauteur (Fig. 22-3) dans le sens de la pleine position **ON** (Fig. 22-4) pour allumer le brûleur à BTU maximale. Après le brûleur principal s'allume, ajuster la hauteur de la flamme, comme indiqué dans la section suivante.

RÉGLAGE DE LA HAUTEUR DE LA FLAMME

Pour régler la flamme, tourner le bouton de contrôle de flamme de hauteur (Fig. 22-3) dans le sens antihoraire (vers **ON**) pour augmenter la hauteur de la flamme, ou vers la droite (vers **OFF**) pour diminuer la hauteur de la flamme, jusqu'à ce que les flammes ont les caractéristiques souhaitées.

Remarque: En tournant le bouton de contrôle de flamme de la hauteur sur **OFF** permet d'éteindre le brûleur. Le pilote reste allumé. Le système de brûleur peut être rallumé en tournant le bouton de commande à la flamme de la hauteur vers **ON**.

FERMER

BRÛLEUR (pilote reste allumé):

Tournez le bouton de contrôle de flamme de la hauteur dans le sens horaire sur **OFF**.

(Le bouton de commande d'allumage restera dans la position **ON**.)

BRÛLEUR ET LA VEILLEUSE (arrêt total):

Si vous ne prévoyez pas d'utiliser votre système de brûleur pour une longue période (une semaine ou plus), **vous pouvez éteindre le pilote**. Ce sera de conserver l'énergie et économiser de l'argent.

Tournez le bouton de contrôle de flamme de la hauteur dans le sens horaire sur **OFF**, puis tournez le bouton de commande d'allumage dans le sens horaire sur **OFF**.

Important: Si vous désirez rallumer l'appareil, attendez au moins une (1) minute avant de commencer la procédure de rallumage. Ceci permet à la soupape de sécurité à remise à zéro en préparation pour rallumer.

Si cet appareil a été livré avec une télécommande, ou si une distance a été installé plus tard, lisez et suivez les instructions à distance distincts pour faire fonctionner le brûleur à distance.

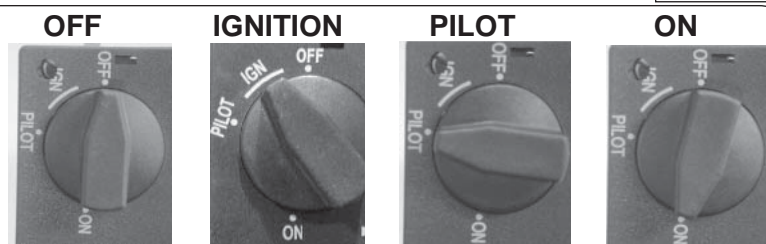

Bouton de commande d'allumage - positions
Fig. 22-1

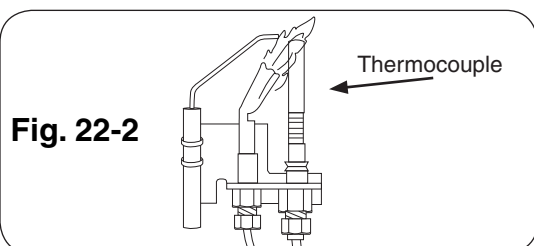

Fig. 22-2

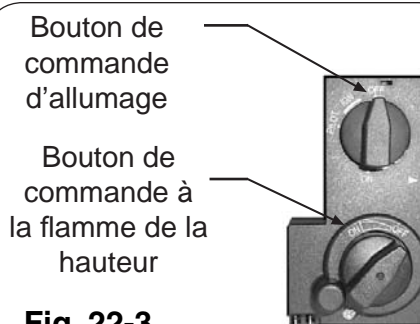
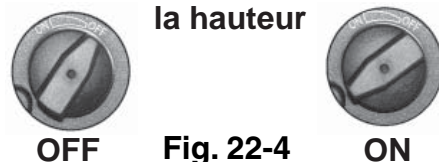

Fig. 22-3

Bouton de commande à la flamme de la hauteur



OFF

Fig. 22-4

ON

LIGHTING INSTRUCTIONS - SERIES 15 VALVE

FOR YOUR SAFETY, READ BEFORE LIGHTING

WARNING

If you do not follow these instructions exactly, a fire or explosion may result, causing property damage, personal injury, or loss of life.

Do not use this appliance if any part has been underwater. Immediately call for a qualified professional service technician to inspect the appliance and to replace any part of the control system and any gas control that has been underwater.

The Real Fyre burner system has a pilot. When starting the pilot, follow these instructions exactly.

BEFORE LIGHTING, smell all around the gas burner system area for gas. Be sure to smell next to the floor, as some gas is heavier than air and will settle on the floor. IF YOU SMELL GAS, FOLLOW THE INSTRUCTIONS ON P. 1.

Use only your hand to push in or turn the gas control knob. Never use tools. If the knob will not push in or turn by hand, don't try to repair it. Call a qualified professional service technician. Force or attempted repair may result in fire or explosion.

LIGHTING THE PILOT

1. Turn the ignition control knob (Fig. 23-1) on the burner control valve assembly (the side of burner pan) counterclockwise so that the narrowing part of the knob moves from the **OFF** position, slightly toward **IGN**, until reaching the stop.
2. Press the ignition control knob in and hold in for five (5) seconds (only pilot gas will flow).
3. Continue pressing in while turning the ignition control knob further counterclockwise toward the **PILOT** position until you hear a click. The click is an indication that the piezo igniter has been activated.

Note: If the spark from the piezo igniter does not light the pilot, repeat steps 2 & 3 until the pilot lights.

4. Continue to hold the ignition control knob in the **PILOT** position for 60 seconds after the pilot has been lit to allow the thermocouple to detect the pilot flame. The pilot will remain lit. **If the pilot fails to light after several tries, turn the ignition control knob to OFF and contact a qualified professional service technician.**

IGNITING THE MAIN BURNER

1. When the pilot flame is stable, release the ignition control knob and turn counterclockwise to the **ON** position to enable the main burner.
2. Turn the flame-height control knob (Fig. 23-3) counterclockwise to the fully **ON** position (Fig. 23-4) to ignite the burner at maximum BTUs. After

the main burner ignites, adjust the flame height as indicated in the following section.

ADJUSTING THE FLAME HEIGHT

To adjust the flame, turn the flame-height control knob (Fig. 23-3) counterclockwise (toward **ON**) to increase the flame height, or clockwise (toward **OFF**) to decrease the flame height, until the flames have the desired characteristics.

Note: Turning the flame-height control knob to **OFF** will turn off the burner. The pilot will remain lit. The burner system can be relit by turning the flame-height control knob toward **ON**.

SHUTTING DOWN

MAIN BURNER ONLY (pilot will remain lit):

Turn the flame-height control knob clockwise to **OFF**. (The ignition control knob will remain in the **ON** position.)

BURNER AND PILOT (total shutdown):

If you do not plan on using your burner system for an extended period (one week or more), **you may extinguish the pilot.** This will conserve energy and save you money.

Turn the flame-height control knob clockwise to **OFF** and then turn the igniter control knob clockwise to **OFF**.

Important: If you desire to turn the unit back on, wait a minimum of one (1) minute before starting the relight procedure. This allows the safety valve to reset in preparation for relighting.

If this unit was shipped with a remote, or if a remote was installed later, read and follow the separate remote instructions to operate the burner remotely.

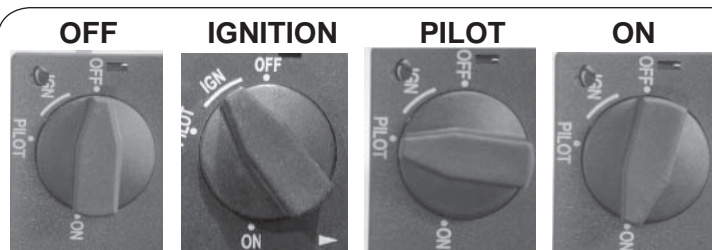

Ignition control knob - positions
Fig. 23-1

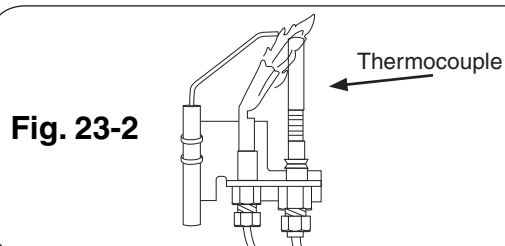

Fig. 23-2

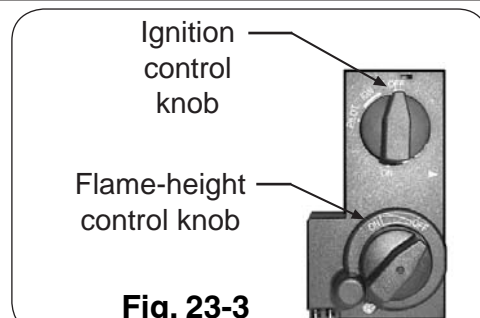

Fig. 23-3



Flame-height control knob

OFF

Fig. 23-4

ON

POUR VOTRE SÛRETÉ, LISEZ AVANT DE S'ALLUMER

AVERTISSEMENT

Si vous ne suivez pas ces instructions exactement, un incendie ou une explosion peut résulter, entraînant des dégâts matériels, des blessures, ou la perte de la vie.

AVANT DE S'ALLUMER, sentez tous autour du secteur de brûleur à gaz pour le gaz. Soyez sûr de sentir à côté du plancher parce qu'un certain gaz est plus lourd que l'air et arrangez sur le plancher. **SI VOUS SENTEZ LE GAZ, SUIVEZ LES INSTRUCTIONS À LA PAGE 1.**

1. **ARRÊT!** Lisez l'information de sûreté ci-dessus.
2. Arrêtez n'importe quel appareil électrique si utilisé avec le système de brûleur.
3. Vérifiez le commutateur (marqué **I = mettez à feu** ; **O = au loin**) situé sur l'avant de la boîte de commutateur est placé au "**O**" ; (AU LOIN). Ne forcez pas.

Fig. 24-1

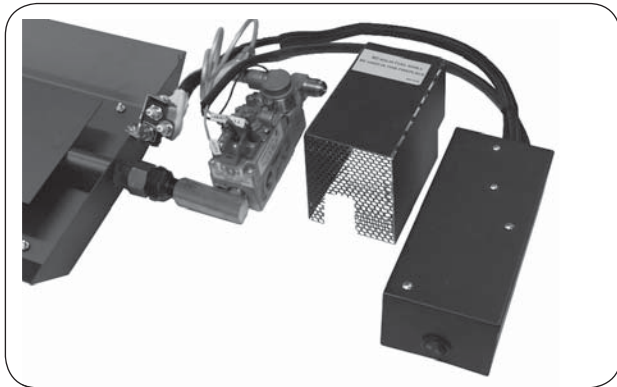

1. ALLUMAGE - vérifiez le commutateur (marqué I = mettez à feu ; O = au loin) situé sur l'avant de la boîte de commutateur est placé aux minutes de l'attente cinq d'O. (5) pour que le gaz se dégage dehors.



1. Serrez "O" (= "off") quand l'arrêt complet est désiré.



2. Pression "I" (= "mettez à feu") après qu'une série d'étincelles rapides que le pilote s'allumera. Quand le pilote est stable, le brûleur principal mettra à feu.

4. Attendez cinq (5) minutes pour dégager dehors n'importe quel gaz. Si vous sentez alors le gaz, **ARRÊTEZ !** Suivez l'information de sûreté ci-dessus. Si vous ne sentez pas le gaz, passez à la prochaine étape.
5. Diminuez le "I" ; (METTEZ À FEU) branchez l'avant de la boîte de commutateur. Ceci transmet une série rapide d'étincelles à la tête pilote. Ces étincelles cessent quand la flamme pilote est allumée et écurie. Le pilote est situé au bon coin arrière du brûleur. Après une brève durée, le pilote allumera le brûleur principal.

ATTENTION: SI L'ENSEMBLE DE GAZ NE MET PAS À FEU DANS 20 SECONDES, ARRÊTEZ, TOURNEZ LE COMMUTATEUR À "OFF", ATTENDENT 5 MINUTES RÉPÉTENT ALORS DES ÉTAPES 3-6.

- **Le pilote devrait rester s'est allumé. S'il sort, répétez l'étape 3 à 6.**
 - **Si le pilote ne restera pas allumé après que plusieurs essais, tournent la boîte de commutateur au "O" ; (AU LOIN) (fig. 24-1) et appelez votre fournisseur de technicien ou de gaz de service.**
6. Pour arrêter l'ensemble, pressez le "O" ; (AU LOIN) branchez l'avant de la boîte de commutateur. L'écoulement de gaz cessera, et toutes les flammes sortiront.

Si cette unité était embarquée avec un extérieur, ou si un système à distance était installé plus tard, lisez et suivez les instructions à distance séparées d'actionner le brûleur à distance.

1. Mettez le commutateur dans la position de repos. Le brûleur s'éteindra et le pilote sortira.

LIGHTING INSTRUCTIONS - SERIES 01 VALVE

FOR YOUR SAFETY, READ BEFORE LIGHTING

WARNING: If you do not follow these instructions exactly, a fire or explosion may result, causing property damage, personal injury, or loss of life.

BEFORE LIGHTING, smell all around the gas burner area for gas. Be sure to smell next to the floor, because some gas is heavier than air and will settle on the floor. IF YOU SMELL GAS, FOLLOW THE INSTRUCTIONS ON P. 1.

1. **STOP!** Read the safety information above.
2. Turn off any electrical appliance used with the burner system.

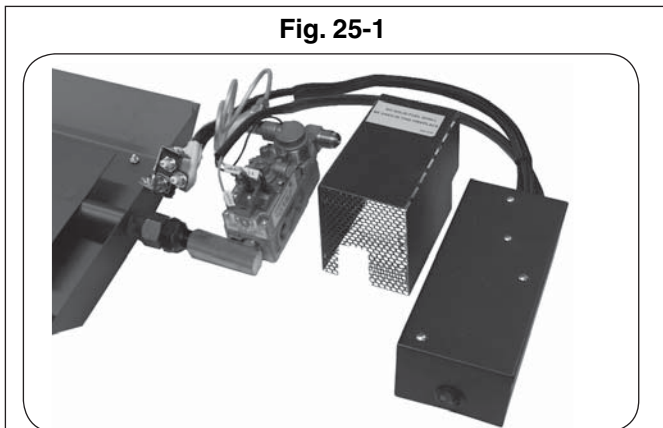

1. **LIGHTING** - Verify the switch (marked **I = IGNITE**; **O = OFF**) located on front of the switch box is set to **O**. Wait five (5) minutes for the gas to clear out.



1. Press **O (OFF)** when complete shutdown is desired.



2. Press **I (IGNITE)**
After a series of rapid sparks, the pilot will light. When the pilot is stable, the main burner will ignite.

3. Verify the switch (marked **I = IGNITE**; **O = OFF**) located on the front of the switch box is set to **"O" (OFF)**. Do not force.
4. Wait five (5) minutes to clear out any gas. If you then smell gas, **STOP!** Follow the safety information above. If you don't smell gas, go to the next step.
5. Depress the **"I" (IGNITE)** switch on the front of the switch box. This transmits a rapid series of sparks at the pilot head. These sparks cease when the pilot flame is lit and stable. The pilot is located at the rear right corner of the burner.

After a short time, the pilot will light the main burner.

CAUTION: IF THE GAS SET DOES NOT IGNITE WITHIN 20 SECONDS, STOP, PRESS **"O" (OFF)**, WAIT FIVE (5) MINUTES, THEN REPEAT STEPS 3-6.

- The pilot should remain lit. If it goes out, repeat steps 3 through 6.
- If the pilot will not stay lit after several tries, turn the switch box to **"O" (OFF)** (Fig. 25-1) and call your service technician or gas supplier.

6. To turn the set **OFF**, press the **"O" (OFF)** switch on the front of the switch box. The gas flow will cease, and all flames will go out.

If this unit was shipped with a remote, or if a remote system was installed later, read and follow the separate remote instructions to operate the burner remotely.

SHUT-OFF INSTRUCTIONS - SERIES 01 VALVE

1. Put the switch in the **OFF** position. The burner will extinguish, and the pilot will go out.

CLEANING AND SERVICING

MAINTENANCE

Once installed and operating properly, your Real Fyre glass burner will require regular maintenance. You should inspect your glass burner and controls (where installed) for the following:

1. Moisture may cause the glass in your burner pan to settle. To improve the burn, follow these tips:
 - a. Settling of glass - Using a screwdriver or flat-blade knife, carefully stir the glass, loosening the material. Clear up any spills.
2. Debris around the control (if equipped)
-Inspect control and pilot to be sure they are free of dirt or debris.
3. **Insects and burner blockage** - Check the burner ports and air shutter, if present, to make sure they are free from debris. Blocked burner ports and orifices may result in a fire at the air shutter.

CLEANING

The pilot assembly (if equipped) must be kept clean and clear of debris at all times for the fireplace burner system to be safely and effectively operated. Dust, carpet fibers, paper, spider webs, pet hair, etc. in the fireplace or on the burner assembly can affect operation of burner and pilot assembly. Vacuum or use compressed air from a can or compressor to clean out pilot assembly area, air shutter holes, burner orifices, and pilot air intake openings. Blockage in this area will affect the operation of pilot assembly.

FLAME DESCRIPTION

Observe the flames. The flames should be blue at the base and a combination of blue/yellow at the body and tips. The flames should be 16" to 18" tall. (See Figure 26-1). Inspect the flames periodically. If flames appear different, contact a professional service technician or your gas supplier to correct the problem.

SERVICING

While some minor service conditions can be handled by the owner of the glass burner, a qualified professional service technician should be called to maintain and service your glass burner and any installed control systems. In addition, a periodic examination and cleaning of the solid-fuel-burning fireplace venting system should be conducted by a qualified professional service technician. The TROUBLESHOOTING section of these instructions serves as a guide for ensuring optimum performance of your glass burner.

To protect your investment in your Real Fyre gas fireplace burner system and keep it operating safely for years to come, maintain, clean, and inspect it regularly. We recommend following these instructions at the beginning of each fireplace season and as needed throughout the year, depending on your usage pattern and the environmental conditions in your home. More frequent cleaning and maintenance may be necessary when burning propane gas than with natural gas.

- Replace all batteries for remote transmitters and receivers if installed.
- Check and readjust the burner air shutter.
- Clean and test the igniter and pilot (if equipped).



PILOT BURNER ADJUSTMENT (IF EQUIPPED)

The pilot burner is preset at the factory and should normally not require any adjustment. However, should adjustment be necessary, the following steps should be taken:

With the pilot burner lit and the control knob in the pilot position, remove the heat shield covers. Adjust the screw located on the control valve (see Fig. 27-1). Using a screwdriver, turn the pilot adjustment screw slowly clockwise to reduce the flame, or counterclockwise to increase the flame.

The adjustment screw can be turned so that the pilot flame is completely extinguished. The pilot flame should be a quiet soft blue flame with yellow tipping that encircles the thermocouple tip.

Replace the heat shield covers. Turn the control knob to the **ON** position to assure proper ignition of the burner system.

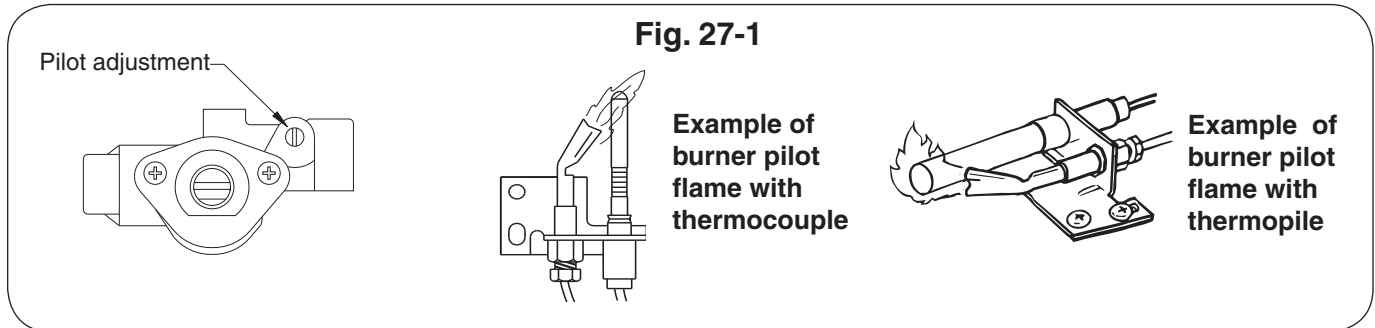

TROUBLESHOOTING

SYMPTOM	CAUSE	SOLUTION
<p>1. Smoking and/or sooting</p> <p>(IMMEDIATELY STOP USING. Call your gas supplier or another qualified professional installer or service agency.)</p>	A. Poor draft or downdraft	A. Check for chimney blockage. Be sure chimney is at least 3' taller than anything within 10' of it in all directions. If not, consult a chimney sweep. Chimney cap or fan may help. Under severe conditions, you may need to open a window near the fireplace about 1" to 2" when burning the unit.
	B. Damper closed	B. Open damper fully when operating burner system.
	C. Burner is positioned too close to the front of the firebox	C. Move burner system to the center of the firebox.
	D. Improper glass/gems placement or amount	D. See PLACEMENT OF GLASS / GEMS section.
	E. Air mixer on propane set is closed	E. Open air mixer completely.
	F. Improper burner for gas used	F. Use only a natural-gas set with natural gas or use only a propane-gas set with propane gas.
<p>2. Low flame</p>	A. Incorrect decorative media for type of gas used	A. Consult your dealer for proper set.
	B. Insufficient gas supply	B. Check gas pressure (Read D. - F. of IMPORTANT PRE-INSTALLATION AND FIREPLACE SAFETY INFORMATION section, & <u>check with local gas company</u>).
	C. Blockage or kink in connector kit, plumbing, or burner orifice	C. Clean out blockage. If connector kit is kinked, replace it.
	D. Valve not fully open	D. Open valve fully.

TROUBLESHOOTING (cont.)

SYMPTOM	CAUSE	SOLUTION
3. Uneven flame distribution (Lower at one end of the burner)	A. Clogged or blocked portholes	A. Clear out burner ports.
	B. Insufficient gas pressure and/or supply	B. Check gas pressure (see Section 2, B of this table).
	C. Decorative media may be packed down too tightly	C. Loosen media around burner pipe by running a kitchen knife along both sides of the pipe. Even out media in burner pan.
	D. Auxiliary shutoff valve partially closed	D. Open valve fully. Usually you will find this along the wall 3' from the fireplace.
4. Flame at air mixer (For propane units)	A. Clogged or blocked burner ports	A. Clear out burner ports.
	B. Insufficient gas pressure and/or supply	B. Check gas pressure (see Section 2, B of this table).
	C. Decorative media may be packed down too tightly	C. Loosen media around the burner by running a kitchen knife along both sides of the pipe. Be sure granules are used with an air mixer.
	D. Excessive gas pressure	D. Contact your gas supplier.

WARRANTY

PETERSON VENTED DECORATIVE GAS APPLIANCE LIMITED WARRANTY

Robert H. Peterson Co. ("RHP") warrants your Real Fyre® vented decorative gas appliance to be free from defects in material and workmanship.

Peterson vented ceramic refractory gas logs are warranted for **as long as you own them (lifetime)**.

Peterson vented burner assemblies are **WARRANTED for TEN (10) YEARS**. Peterson vented outdoor stainless-steel burner assemblies are warranted for **FIVE (5) YEARS**.

Peterson glass, gems, nuggets, and fiber-ceramic blend gas logs are warranted for **FIVE (5) YEARS**.

SPK-26 controls are warranted for **THREE (3) YEARS**.

APK-17 controls (including -17 valve) are warranted for **TWO (2) YEARS**.

All other Peterson valves, pilots, and controls are warranted for **ONE (1) YEAR (excluding batteries)**.

A COPY OF YOUR SALES SLIP FOR PROOF OF PURCHASE IS REQUIRED

This warranty applies to the original purchaser for products which are installed in the United States or Canada and which are operated and maintained as intended for single family residential usage. This warranty is valid only with proof of purchase, shall commence on the date of purchase, and shall terminate (both as to original and any replacement products) on the anniversary date of the original purchase of the product stated on the above schedules.

This warranty covers defects in material and workmanship. This warranty **does not** cover parts which become defective as a result of negligence, misuse, use not in compliance with the Owner's Manual/Installation Instructions, accidental damage, improper handling, improper storage, improper installation, **lack of required routine maintenance** (as specified in the Owner's Manual/Installation Instructions), electrical damage, local gas impurities or failure to protect against combustibles. Product must be installed (and gas must be connected) as specified in the Owner's Manual/Installation Instructions by a **qualified professional installer**. Modifications to products which are not specifically authorized will void this warranty. Accessories, parts, valves, remotes, etc. when used must be Peterson products or this warranty is void. Warranted items will be repaired or replaced at Peterson's sole discretion. This warranty **does not** apply to rust, corrosion, oxidation, or discoloration unless the affected part becomes inoperable.

This warranty **does not** cover labor or labor related charges, except as provided by separate specific written programs from the Peterson Co. All repair work must be performed by a qualified professional service person and requires prior approval of Peterson.

Peterson may require the defective product or part to be returned to the factory to determine the cause of failure. Peterson will pay freight charges if the product or part is determined to be defective. This warranty does not cover breakage in shipment from our (Independent) distributor to its customer if the damage is determined to have occurred during that shipment.

This warranty specifically excludes liability for **indirect, incidental**, or consequential damages. Some states and provinces do not allow the exclusion or limitation of incidental or consequential damages, so the above exclusion may not apply to you. This warranty gives you specified legal rights, and you may have other rights that vary from state to state or province.

For additional information regarding this warranty, or to place a warranty claim, contact the R. H. Peterson dealer where the product was purchased.

When contacting your Peterson dealer or the R. H. Peterson Co., please provide the following information:

- Your name, address, telephone number, e-mail
- Sales receipt showing where purchased and date purchased
- Model number, serial number of product, date code
- Relevant information: installer, additions, repairs, when defect was first noted

**TO REGISTER YOUR PRODUCT ONLINE GO TO: WWW.RHPETERSON.COM,
AND CLICK ON PRODUCT REGISTRATION. THANK YOU FOR YOUR PURCHASE.**

Quality Check			Date: _____		
Burner Orifices	Nat.	L.P.	Leak Test: _____	Model#:	_____
Main:	_____	_____	Burn Test:	Serial#:	_____
Other:	_____	_____	Gas Type:	Nat. / L.P.	Air Shutter: _____
				Inspector:	_____